

IP WatchDog

Dual monitor of Ethernet and serial devices with automatic reset function

IP-WatchDog



Shipment contents

Complete shipment of IP Watchdog contains following items:

- IP Watchdog in metal case and mechanic version according to the ordering number.
- Serial extension cord 1:1 (DB9F - DB9M) for device configuration via RS-232.
- Power adaptor (European version).
- Manual.
- CD containing necessary software.

Default network parameters configuration:

IP address: 192.168.1.60

Network mask : 255.255.255.0

Default gateway: 192.168.1.1

IP configuration via DHCP: Enabled

User name: Not set

Password: Not set

Table of contents

Shipment contents	3
Default network parameters configuration:	3
Table of contents	4
Characteristics and basic properties	5
Basic properties	5
Connection topology	6
Suitable for	6
Main WatchDog functions.....	6
Technical parameters	7
Connectors and connection points	9
Connection and basic configuration	10
Device connection	10
Primary configuration of Ethernet parameters	11
Configuration troubleshooting	13
Device configuration via WWW	14
IP WatchDog Main Page	14
IP-WatchDog Channel Admin Page.....	16
IP WatchDog Setup Page.....	19
IP WatchDog – File Upload	20
Description of configuration parameters	21
Device's default configuration	21
Device's network parameters	22
Securing by restricting the range of IP addresses	22
Securing access to WWW interface administration	23
Other device parameters	23
Application hints	25
Security.....	25
Time protocol.....	25
NTP	26
SNTP	26
Testing and operation hints for Windows and Linux	27
Testing the function of Incoming Ping.....	27
Testing the Outgoing HTML Page function.....	29
Mechanical dimensions	30
Device versions	31
Contact	32

Characteristics and basic properties

IP WatchDog is a device intended for monitoring Ethernet and serial (RS232, RS485) devices provided by tracking the serial communication, ICMP ping function or requesting the WWW page. By the means of these functions it can RESET up to two monitored devices, such as servers, routers, access and security systems.



Basic properties

- **Ethernet** - RJ45 (10BASE-T - IEEE 802.3).
- **1x RS-232 serial port** (RxD, TxD, CTS, RTS, GND) - Setup mode 9600 8N1
- **1x RxD serial channel input**
- **Automatic reset or start of 2 devices** in terms of monitored actions.
- **Methods for monitoring Ethernet devices:**
 - **Incoming / Outgoing ping**
 - **Incoming / Outgoing WWW page**
- **Monitoring two RS-232 serial devices** - IP WatchDog awaits the defined string on a serial port in regular intervals.
- **Two independent relays for resetting or starting monitored devices**
Available contact configurations can be found in the table at the end of this manual.
- **Manual attendance (startup/shutdown/restart)** of the monitored devices.
- **Time synchronization from internet / intranet using protocols :**
 - **TIME** – older but simple and popular protocol (UDP port 37).
 - **NTP/SNTP** – most used time synchronization protocols (UDP port 123).
 - **DayTime** – protocol which is implemented in Windows (TCP/UDP port13).
- **Configuration methods:**
 - **WWW page** – device's behaviour configuration including manual relay attendance.
 - **RS-232 Setup** – main parameters configuration over serial port from any RS-232 terminal - 9600 8N1.
 - **UDP Setup** – configuration of main network parameters.
 - **TCP Setup** – remote configuration of basic parameters in terminal over TCP.
- **Access security** and relay control:
 - It's possible to define the range of IP which will be allowed to communicate with the device.
 - Access to WWW pages can be restricted to certain user names and passwords.
 - Serial / TCP setup can be secured by user name and password.
- **Power supply 9-15 V DC.**
- Metal box dimensions: 25 x 82 x 90 [mm].
- **Master Reset** – restoring the default configuration

Connection topology

IP WatchDog is based on the Charon II Ethernet module and it is intended for control and reset of the Ethernet devices. It's equipped with the functions such as **sending and receiving ICMP command - PING** on the defined IP address(es). When monitoring by sending this command it is possible to enter up to two target IP addresses (primary and secondary) so it could be possible to eliminate the inactivity of the whole device in case one IP address is unavailable.

Monitoring Ethernet devices (http servers) allows **requesting WWW pages** from the monitored device. When a valid http title is received the monitored device is considered as operational. *IP WatchDog* **uses its own HTML page** providing information on channel number it comes from, IP address from which the request for WWW page is accepted and client's IP address, which requested the page.

IP WatchDog has a pair of serial ports, which can be used for **monitoring the activity of RS-232 devices** and at the same time they allow basic WatchDog configuration.

Suitable for

- servers
- routers
- ADSL and cable modems
- WIFI AP
- Security and access systems
- Accumulators

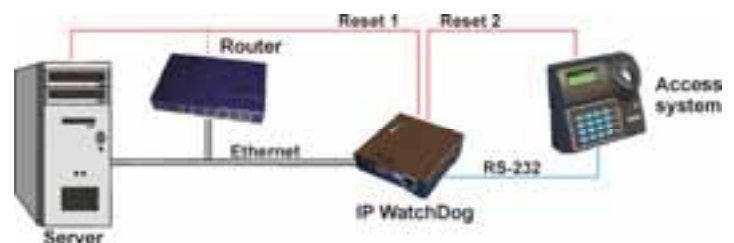

Main WatchDog functions

- Monitoring Ethernet devices using **incoming ICMP command - PING**.
IP WatchDog awaits incoming ping from the monitored device in preset intervals.
- Monitoring Ethernet devices using **outgoing ICMP command - PING**.
IP WatchDog sends in regular intervals a ping command to the defined IP address and awaits a reply. It's also possible to set a secondary IP, used in case the primary address is engaged.
- Monitoring HTTP servers' activity by **requesting a WWW page**.
IP WatchDog regularly requests a WWW page from a monitored device (suitable in case the target IP has the ping function blocked.)
- Monitoring the activity of HTTP clients by **providing a WWW page**.
IP WatchDog awaits requests for its own WWW page in regular intervals. Suitable for systems without own WWW server
- Monitoring the data flow of the RS-232 line by **awaiting requested string**.
IP WatchDog awaits in regular intervals a specific string on a serial port.
- **Reset** of monitored devices or **Starting** backup systems in case of a dropout.
- **Manual attendance** of both channels.

Technical parameters

Ethernet port	
+ Interface	RJ45 (10BASE-T / 100BASE-Tx)
+ Compatibility	Ethernet: version 2.0/IEEE 802.3
+ Supported protocols	IP: ARP, TCP/IP, NVT, RFC2217, UDP/IP, TIME, NTP, SNTP, DAYTIME
Serial port 1 DB9F – Serial Setup / Channel 1	
+ Data bits	8
+ Stop bits	1
+ Parity	None
+ RS-232 Interface	RxD,TxD,RTS,CTS,GND
+ Baud rate	Configurable in range from 50..115200 Bd
Serial port 2 DB9M – Channel 2	
+ Data bits	8
+ Stop bits	1
+ Parity	None
+ RS-232 Interface	RxD on pin 7
+ Baud rate	Configurable in range from 50..115200 Bd
Možné konfigurace kontaktů relé *	
PO (<i>Power On</i>)	Contacts A and B: when started the external supply voltage is lead out over (A = +, B = GND) breaking contact.
PF (<i>Power Off</i>)	Contacts A and B: when turned on, the A and B terminals are unpowered (1 = +, 2 = GND); switching contact
NO (<i>normally opened</i>)	Contacts A and B: switching contact is lead out. When the power supply is turned on it's open.
NC (<i>normally closed</i>)	Contacts A and B: break contact is lead out. When the power supply is turned on it's closed
Relay contact ampacity	
DC voltage	max. 50V / 1A
AC voltage	max. 100V / 2A
Environment parameters	
+ Operation temperature	-5 to +50 °C
+ Storage temperature	-5 to +75 °C
+ Relative humidity (non-condensing)	5 to 95 %
LED diods	
+ POWER (green)	Power supply on.
+ LINK & Activity (green)	Ethernet connection.
+ Channel 1 (yellow)	<i>Quick blinks</i> – channel 1 in Reset state. <i>Short blink</i> – receiving requested monitored information at channel 1 (ping, HTML page, string on RS-232).
+ Channel 2 (yellow)	<i>Quick blinks</i> – channel 2 in Reset state. <i>Short blink</i> – receiving requested monitored information at channel 2 (ping, HTML page, string on RS-232).
+ Setup / NTP (red)	<i>Quick blinks</i> – device in Setup (Serial/TCP) state. <i>Short blink</i> – time synchronization.

DIP switches	
+ DIP1 - RS-232 Setup	ON = RS-232 Setup mode (9600 8N1) OFF = Ethernet mode
+ DIP3	ON = securing serial / TCP setup by user name and password (if configured). OFF = without security
+ DIP2, DIP4	Unused.
Monitored functions and parameters	
+ Incoming Ping	IP range – range of IP addresses defined by IP and mask, from which the receiving PING can be accepted. Timeout delay for reboot – time interval, in range from 0-1800 s (0 = disabled), that IP WatchDog waits for incoming PING before causing RESET.
+ Outgoing Ping	Primary target IP – primary IP address where IP Watchdog sends the PING and from which it awaits reply. Secondary target IP – secondary IP address where IP Watchdog sends the PING and from which it awaits reply, if primary target does not responds. Quantity of failed ping for reboot – number of PINGs, that IP Watchdog assumes for lost before causing RESET. Outgoing ping interval – interval between sent PINGs in range of 0-1800 s (0 = disabled).
+ Incoming HTML page (WWW client)	Server IP – IP address, which IP WatchDog requests HTML page from. Timeout delay for reboot – time intervals, in range of 0-1800 s (0 = disabled), between RESETs, which are performed if IP WatchDog does not receive required string in the HTML page. Reading HTML page period – interval between requests for WWW page within the range of 0-1800 s (0 = disabled). Incoming string inside incoming HTML page – string in ASCII, HEX or DEC format, that is searched within the HTML page (* stands for any character).
+ Outgoing HTML page (WWW server)	Request Page – HTML page address offered to the monitored device. Provides channel number and information about acceptable IP address and client's IP address which requested the page. Device IP – IP address of the monitored device's WWW client, from which the request for HTML page was accepted. Timeout delay for reboot – time interval, from the range of 0-1800 s (0 = disabled), that IP Watchdog awaits the request for HTML page before performing RESET.
+ Incoming RS232 String	Incoming string – string in ASCII, HEX or DEC format which is expected on the RS-232 port (* stands for any character). Timeout delay for reboot – time interval, from the range of 0-1800 s (0 = disabled), that IP Watchdog awaits the requested string before causing RESET.
Other parameters	
+ Time synchronization interval	1800 s
+ Power supply	12-15 V/ 150 mA DC- coaxial power connector, GND on circuit.
+ Dimensions	25 x 82 x 90 [mm] (H x W x D).
+ Mounting method	Separate box, "L" profiles or mounting to DIN molding.
+ Weight	450 g

Connectors and connection points

Distribution of connectors and operating elements and relay connection is depicted below:

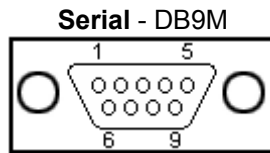
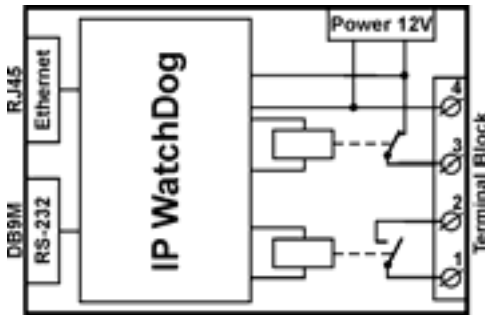

Connector DB9M (RS-232)				
	Channel 1	Channel2		
1			-	Unused
2	TxD		-->	Transmit Data
3	RxD1		<--	Receive Data
4			-	Unused
5	GND		---	System Ground
6			-	Unused
7*	CTS	RxD	<--	Clear to Send, (Receive Data)
8	RTS		-->	Request to Send
9			-	Unused

* In the Setup mode it works as CTS for configuring UART. In the operation process it works as a data input for channel 2.

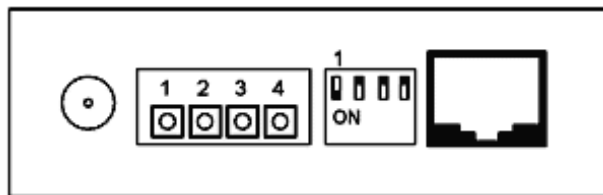

Terminal board description			
Pin	Output	Power	The contact function depends on the supplied configuration. More information about contact types can be found at the end of this page
1	CH1 A	PWR (+)	
2	CH1 B	GND (-)	
3	CH2 A	PWR (+)	
4	CH2 B	GND (-)	

Description of DIP switches	
DIP1	ON RS-232 SETUP mode OFF = Operating mode
DIP2	Unused
DIP3	ON = Setup mode and WWW secured OFF = No security
DIP4	Unused

Switching the DIP1 during the first 5 seconds since power-on will cause Master Reset, which restores all factory configuration. All user's settings, including IP and passwords will be lost!

Unlabeled RJ-45 and RJ-11 connectors next to the serial port are reserved for customer's applications and are not connected

Connection and basic configuration

In this chapter you will learn connecting the IP WatchDog easily to your PC or company network, setting it up the way it would satisfy your needs and putting it into service.

Device connection

The following procedure is recommended for quick setup of the device. Detailed description of all parameters and commands can be found in the chapter called “Parameters description”.

Cable connection

- Set switches from DIP1 to DIP4 into OFF position.
- Connect IP WatchDog to the Ethernet 10 Mbit or 10/100 Mbit network. For direct connection to the PC use a crossed TP cable, and for connection to hub/switch/router use classic TP patch cable.
- If you are planning to connect some RS-232 device to the WatchDog, connect it using the supplied Laplink cable (Serial1 interface RS-232 is on the DB9F connector).
- Connect the supplied power adaptor to supply network and plug the connector of the power adaptor into the power connector of the IP relay. The *Power* LED indicator should light up.
- If the Ethernet connection is OK, the LINK indicator should light up and then blink according to the data transfer to the Ethernet (Activity signalization).
- ***If there is a server in the DHCP network, the IP WatchDog requests the address from it and it will be available immediately on this assigned IP address. In other case it will be, after 60 seconds, available on the default IP 192.168.1.60***

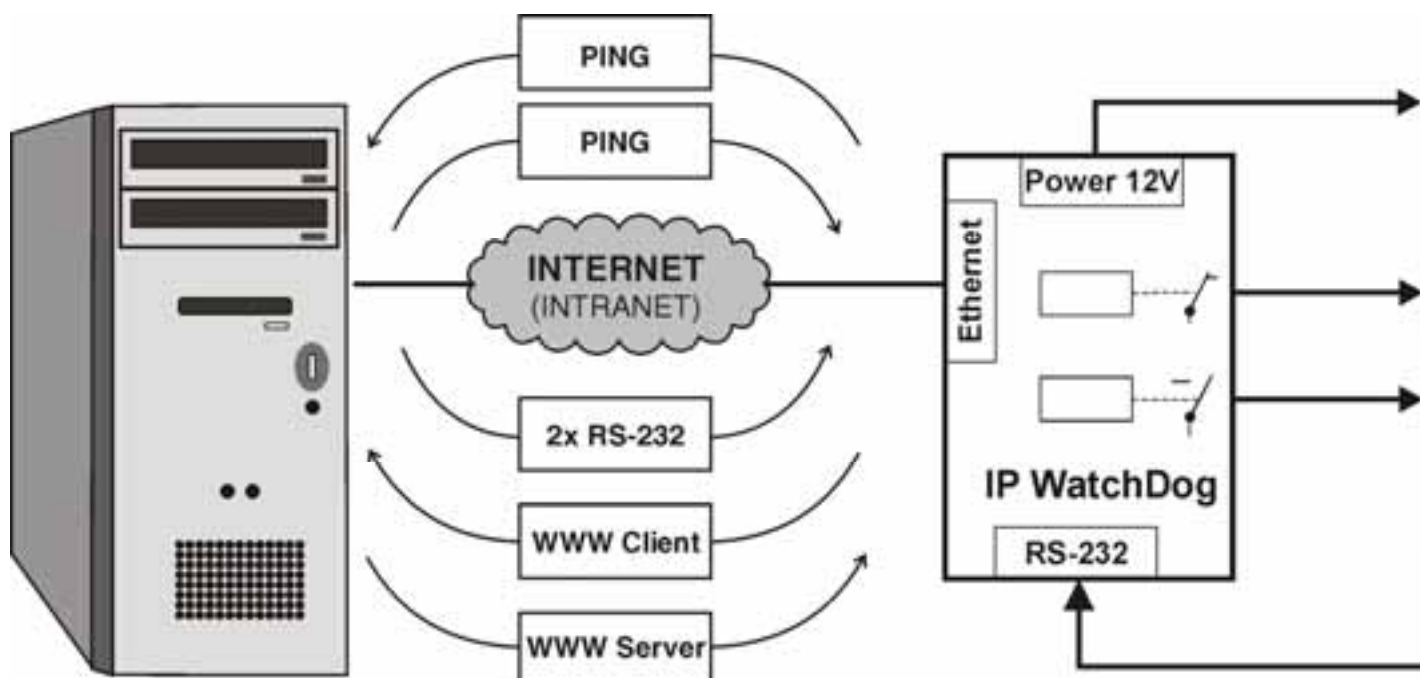

IP WatchDog connection topology

Primary configuration of Ethernet parameters

The primary configuration of the IP WatchDog's Ethernet parameters (IP address, network mask and gateway) can be achieved by the following means:

- **UDP Setup** – *IP WatchDog* must be located on a local Ethernet network segment.
- **RS-232 Setup** – In case no Ethernet connection is available.
- **TCP Setup** – only if you know the IP address of the device! *TCP setup* allows setting the same parameters as *Serial Setup*. It also allows changing the parameters remotely via Ethernet / Internet.

UDP Setup – Searching the device using UDP setup

- Launch the program by „*HerculesSetup.exe*“, which can be found in the root directory of the supplied CD. The latest version of the program can be also downloaded for free from our web pages - www.HWgroup.cz.
- In the „*UDP Setup*“ tab, press the „*Find modules*“ button (step 1). The device's MAC address should appear in the left column.
- Click on the MAC address (step 2). In the field „*Required parameters*“ the configured device parameters should appear.
- See to it that the „*Enable TCP Setup*“ field is checked and by pressing „*Set module*“ (step 4) save the parameters.

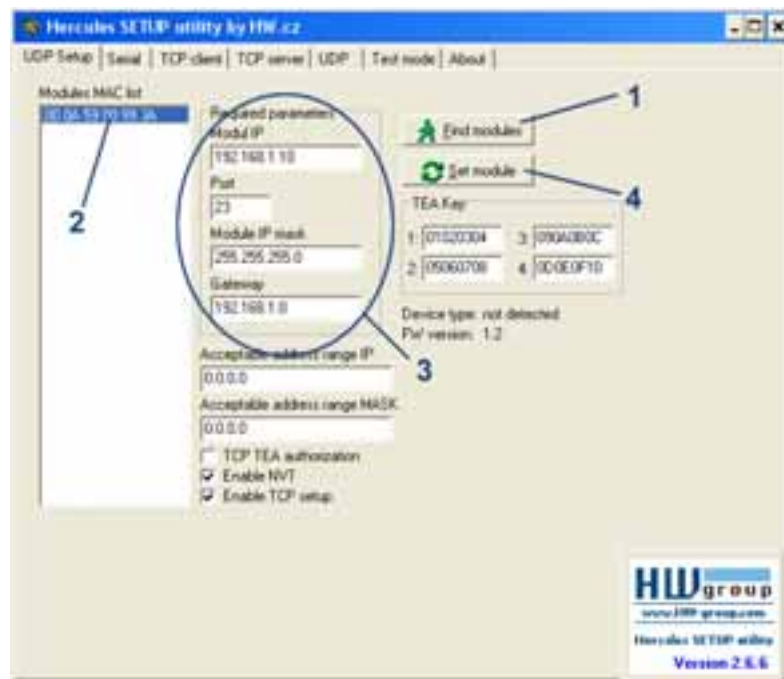

Note: If you wish to change these basic parameters (it's necessary to set at least the IP address, port, mask and gateway), enter the desired parameters into proper fields and press the „*Set module*“ button (step 4).

Enter the IP address of the device into your WWW browser and press Enter. You will get a Main Page of the www interface.

Detailed information on configuration methods over www interface can be found in the chapter called **Device configuration via WWW**.



Connection to IP WatchDog using terminal and RS-232 Setup

Below you will find description of the supplied Hercules Setup Utility program. If you do not have this program you can set the device using any RS-232 terminal.

- Disconnect the device's power adaptor.
- Set DIP1 = ON, DIP2 = OFF, DIP3 = OFF, DIP4 = OFF.
- Connect the device to PC using supplied RS-232 cable. Use Port 1 (DB9F) at the IP relay.
- Go to the "Serial" tab of the Hercules Setup Utility.
- Set the proper serial port and communication parameters - **9600 8N1** (step 1).
- Press the „Open“ button.
- Connect the power adaptor to the power connector of the IP relay, the green Power indicator should light up.
- List of configuration parameters should now appear in the „Received/Sent data“ window.
- Desired parameter can be set using the letter of the corresponding option and proper value. (Example: „l192.168.6.8“ for configuration of device's IP address).

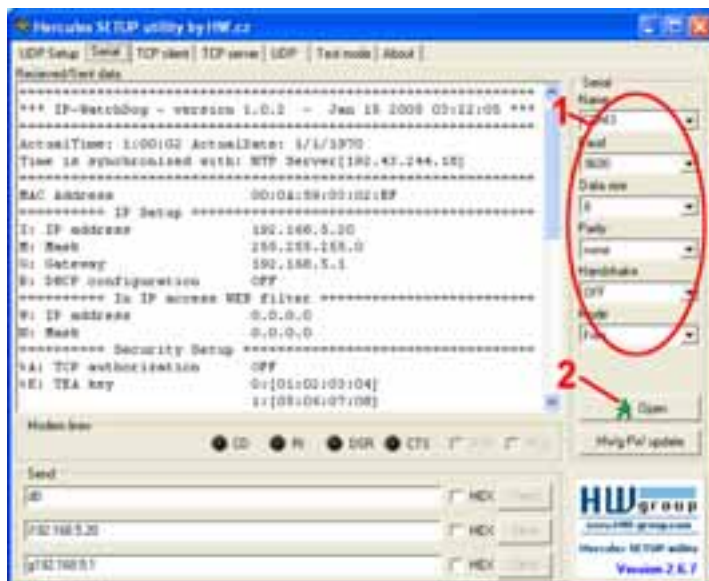

Connection to IP WatchDog using terminal and TCP Setup

- Go to the „TCP Client“ tab.
- Enter the preset IP address to the „Module IP“ field (step 1).
- Into the „Port“ field enter „99“ (step 2), no matter which port you have set for communication with the device. (Port 99 is reserved for TCP setup).
- Press the „Connect“ button (step 3).
- The prompt „WEB51>“ will appear in „Received / Sent data“ window. Click into this field and press Enter. The window will be filled with actual parameter configuration.
- Specific parameters can be set by choosing the letter of the corresponding option and proper value (example: „l192.168.6.8“ for configuration of device's IP address).



Note: Complete list of parameters and commands with detailed descriptions can be found in chapter **“Description of configuration parameters”**.

Help for the commands is available through sending command in format **“command?”** and pressing Enter. Example: **“l?”** + Enter.

When configuration is done, you must restart the device with the **“R”** command. Disconnect by pressing the **“Close”** button.

Serial Setup can be closed temporarily by **“x”** command. Don't forget to switch DIP1 back to the OFF position when you finished your work, or IP WatchDog will not be able to communicate via Ethernet.

Configuration of basic network parameters using a terminal program

For primary launch the IP WatchDog needs to have configured only several main Ethernet parameters – the IP address, network mask and gateway which can be found in the **IP Setup** section.

- **WatchDog's IP address**

I: IP address 192.168.6.19

Entry example: I192.168.6.4

- **Network mask**

M: Mask 255.255.255.0

Entry example: M255.255.255.0

- **Default gateway**

G: Gateway 192.168.6.1

Entry example: G192.168.6.1

Note: Serial Setup allows setting lots of other parameters. These, though, are more easily configurable via Ethernet using the Hercules Setup Utility or via WWW interface. Detailed description of configuration parameters of the terminal Setup can be found in chapter “**Description of configuration parameters**”.

Configuration troubleshooting

The **MAC address of the device did not appear in the “Modules MAC list” or the device does not communicate over Ethernet.**

- Check the power adaptor's connection (the Power indicator of the device must be lit).
- Your Ethernet network must support 10 Mbit devices.
- Check whether you are using a correct TP cable (TP Patch cable for connection to a hub/switch/router; crossed TP cable for direct connection to a PC).
- Check configuration of DIP switches of the device (all should be in OFF position). **If DIP1 is ON, the device is in RS-232 Setup mode and will not communicate over Ethernet.** After switching DIP1 into OFF position, it's necessary to restart the device by cutting the power supply for at least 3 seconds.
- If you are using firewall, make sure it does not block communication with the device.

Device configuration via WWW

IP WatchDog contains a WWW interface allowing easy and detailed attendance of the device activity. The interface consists of four HTML pages which can be called by entering IP address of the device from your web browser.

IP WatchDog Main Page

After entering WatchDog's IP address to the web browser you will get a main page showing the basic parameters of WatchDog's channels and statistics for the last 20 operations of each channel. In the upper part of the screen you can see links for advanced properties configuration of the IP WatchDog:

The screenshot shows the IP-WatchDog Main Page in a Microsoft Internet Explorer browser. The page title is "IP-WatchDog Main Page". The browser address bar shows "http://192.168.5.60/cgi-bin/index.cgi". The page content is as follows:

Refresh page for: 5s **Refresh now**

Channel 1

Device name	device1
Channel	Enabled
Channel type	PO (Power On)
Initial Channel state	Power On
Monitoring method	Outgoing Ping
Monitoring period	120s
Channel state	Device Checking Waiting for refresh pulse
Manual Reboot	Ch1:ManualReboot

Last 20 Actions

Date	Time	Action
17.7.2005	23:13:35	Ch1: Manual reboot: from website
17.7.2005	23:13:40	Ch1: Run
17.7.2005	23:13:40	First synchronizations of time
1.1.1970	1:00:01	Ch1: Ready
1.1.1970	1:00:01	^^ IP-WatchDog: startup ^^
17.7.2005	22:12:37	Ch1: Run
17.7.2005	22:12:37	First synchronizations of time
1.1.1970	1:00:01	Ch1: Ready
1.1.1970	1:00:01	^^ IP-WatchDog: startup ^^
17.7.2005	22:12:16	Ch1: Run
17.7.2005	22:11:53	First synchronizations of time
1.1.1970	1:00:01	Ch1: Ready
1.1.1970	1:00:01	^^ IP-WatchDog: startup ^^
17.7.2005	22:11:01	First synchronizations of time
1.1.1970	1:00:01	Ch1: Ready
1.1.1970	1:00:01	^^ IP-WatchDog: startup ^^
17.7.2005	22:10:54	First synchronizations of time
1.1.1970	1:00:01	Ch1: Ready
1.1.1970	1:00:01	^^ IP-WatchDog: startup ^^
17.7.2005	22:10:45	Ch1: Shutdown

Channel 2

Device name	device2
Channel	Enabled
Channel type	NO (Normally Open)
Initial Channel state	Open
Monitoring method	Outgoing Ping
Monitoring period	120s
Channel state	Device Checking Waiting for refresh pulse
If have allowed access	Ch2:ManualReboot

Last 20 Actions

Date	Time	Action
17.7.2005	23:13:19	Ch2: Manual reboot: from website
17.7.2005	23:13:41	Ch2: Run
17.7.2005	23:13:40	Ch2: Ready
17.7.2005	23:13:40	First synchronizations of time
1.1.1970	1:00:01	^^ IP-WatchDog: startup ^^
17.7.2005	22:12:38	Ch2: Run
17.7.2005	22:12:37	Ch2: Ready
17.7.2005	22:12:37	First synchronizations of time
1.1.1970	1:00:01	^^ IP-WatchDog: startup ^^
17.7.2005	22:12:10	Ch2: Run
17.7.2005	22:11:53	Ch2: Ready
17.7.2005	22:11:53	First synchronizations of time
1.1.1970	1:00:01	^^ IP-WatchDog: startup ^^
17.7.2005	22:11:16	Ch2: Manual reboot: from website
17.7.2005	22:11:01	Ch2: Ready
17.7.2005	22:11:01	First synchronizations of time
1.1.1970	1:00:01	^^ IP-WatchDog: startup ^^
17.7.2005	22:10:54	Ch2: Ready
17.7.2005	22:10:54	First synchronizations of time
1.1.1970	1:00:01	^^ IP-WatchDog: startup ^^

Displayed data

- **Refresh page stop (Refresh page for):** - Interval of the *Main Page refresh* (see *Setup Page*).
- **Refresh now** – Immediately refreshes the *Main Page*. Because of used scripts it's not possible to use browser's *Refresh (F5)*.
- **Device name** – name of the monitored device (see *Channel Admin Page*).
- **Channel** – information on closing or opening of the channel (*Enable / Disable*).
- **Channel type** – Information on relay pin configuration of the given channel (*PO / PF / NO / NC* – see chapter **Device versions**)
- **Initial Channel State** – channel state after startup (*Open / Close / PowerOn / PowerOff*) depending on configuration used (see chapter **Device versions**).
- **Reboot Channel State** – channel state after reset (*Open / Close / PowerOn / PowerOff*) depending on configuration used (see chapter **Device versions**).
- **Monitoring method** – actual function assigned to the channel (see *Channel Admin Page*):
 - **Incoming Ping** – IP WatchDog waits for ICMP command - PING from the defined address or range of addresses defined by IP and mask.
 - **Outgoing Ping** – IP WatchDog sends the ICMP command PING to the defined primary IP address and awaits response. If not received, the same command is sent to the secondary IP.
 - **Outgoing HTML page** – IP WatchDog requests the HTML page from WWW server located on the defined IP address.
 - **Incoming HTML page** – IP WatchDog awaits the request for own WWW page from the device defined by IP address.
 - **Incoming RS232 String** – IP WatchDog monitors the data on RS-232 port and awaits required string.
- **Monitoring period** – maximal interval between resetting impulses.
- **Reboot Hold Time** – the length of a reboot impulse (see *Channel Admin Page*)
- **Channel state** – information on actual channel state:
 - **Channel Inactive** - channel is deactivated. Allows manual relay attendance using *Channel Admin Page*.
 - **Device Checking** – Channel waits for refreshing impulse.
 - **Device Idle** – Channel was reset. Awaiting first refreshing impulse.
 - **Power Cycle Reboot** - Performing channel reset.
 - **Manual WWW reboot** – *Channel was reset manually*.
- **Manual Reboot** – Resetting button.
- **Last 20 Actions** – last 20 stored actions:
 - **--- IP-WatchDog: startup ---** starting IP WatchDog
 - **First synchronizations of time** – synchronization by NTP/Time/DayTime server.
 - **Ready** – after Watchdog's turning on/reset the channel is ready
 - **Shutdown** – channel shutdown.
 - **Run** – channel start.
 - **Automatic reboot** – automatic Reset.
 - **Manual reboot: from website** – manual reset from WWW page.
 - **Reset by response to outg. ping** – received the response for outgoing PING.
 - **Reset by response to inc. ping** – received an incoming PING.
 - **Reset: by incoming HTML page** – requested WWW page received.
 - **Reset by response to inc. HTML page** – request for HTML page accepted.
 - **Reset by response to inc. RS232 String** – received a valid RS-232 string.

IP-WatchDog Channel Admin Page

HTML pages IP-WatchDog Channel 1 Admin Page and IP-WatchDog Channel 2 Admin Page allow complete administration of the monitored channels.

IP-WatchDog Channel 1 Admin Page

Channel 1 Setup

Device name <small>(max. 20 characters)</small>	device1	Channel	<input type="radio"/> Disabled <input checked="" type="radio"/> Enabled
Reboot Hold Time <small>(Reboot state hold)</small>	5 [s] <small>(1-1800)</small>	Channel type:	P0 (Power On)
Timeout After Reboot <small>(Time to activate WatchDog function after target device's reboot. 0 = waiting for the first "Living" pulse.)</small>	5 [s] <small>(0-1800)</small>	Initial Channel state	Power On
		Reboot Channel state	Power Off

Reset by Ping

Incoming Ping		Outgoing Ping	
IP range <small>(Refresh enabled by ping from IP address range defined by this filter)</small>	IP: 192.168.0.1 Mask: 255.255.255.255	Primary target IP	192.168.0.1
Timeout for reboot <small>(1-1800)</small>	120 [s]	Secondary target IP	192.168.0.144
	<input type="button" value="Save values"/>	Quantity of failed ping for reboot	20
		Outgoing ping interval <small>(1-1800)</small>	120 [s]
			<input type="button" value="Save values"/>

Monitoring by HTML page

HTML page (TCP Server) <small>Device request HTML page from the IP-WatchDog</small>		WWW page Request (TCP Client) <small>IP-WatchDog check opposite device's Web page (TCP Client)</small>	
Request Page	http://192.168.5.60/cgi-bin/refreshpage1.cgi	Server IP	192.168.0.1
Device IP	192.168.0.1	Timeout for reboot <small>(3-1800)</small>	120 [s]
Timeout for reboot <small>(1-1800)</small>	120 [s]	Failed attempts to read HTML page <small>(3-1800)</small>	6
	<input type="button" value="Save values"/>	Requested string inside HTML page	<input type="button" value="ASCII values"/> <input type="button" value="DEC values"/> <input type="button" value="HEX values"/> <input type="button" value="OK"/> <small>For HEX use \$ as prefix For DEC use # as prefix For ASCII use <CASEE_NAME> * = any single character # = character *</small> EXAMPLE: "\$OK+CR+LF\$" "#OK+CR+LF#" "#079#075#022#020" "\$#F#4#E#C#3A\$" "\$#F#4#E#D#2#0x\$" <input type="button" value="Save values"/>

Monitoring by RS-232 String

Requested RS-232 string		Timeout for reboot <small>(1-1800)</small>	120 [s]
Requested string	<input type="button" value="ASCII values"/> <input type="button" value="DEC values"/> <input type="button" value="HEX values"/> <input type="button" value="OK"/> <small>For HEX use \$ as prefix For DEC use # as prefix For ASCII use <CASEE_NAME> * = any single character # = character *</small> EXAMPLE: "\$OK+CR+LF\$" "#OK+CR+LF#" "#079#075#022#020" "\$#F#4#E#C#3A\$" "\$#F#4#E#D#2#0x\$" <input type="button" value="Save values"/>		

Channel 1 Setup

- **Device name** – Makes orientation easier when configuring channels and solving the problems with the monitored device. It can contain at most 20 characters.
- **Reboot Hold Time** – duration of the Reset state. Allows setting time when the channel/relay stays in reset state (manual or automatic). Duration can be set from interval 1-1800 seconds. If this parameter is set to “0” then the Reset state lasts until the next refreshing impulse comes. This mode is suitable for activation of the backup device or identification of the error state using other signalization means. More information can be found in the *Reboot Hold Time* paragraph of the chapter “**Application hints**”.
- **Timeout After Reboot** – time interval that IP WatchDog waits before causing other Reset after previous one (or after first launch of the device), if monitored data are not received. The Interval can be from range of 0-1800 seconds. The “0” value causes device to wait for first incoming data from the monitored device.
- **Channel enabled/disabled** – enables/disables a channel. If the channel is deactivated, the additional **Manual Control** button will be available above the *Save values* button:
 - **ManualControl : Initial State** – indicates a default channel state (or relay). Pressing the button changes the state to reset state.
 - **ManualControl : Reboot State** – indicates channel state (or relay) in reset level. Pressing this button changes the state to idle state.

- **Channel type** – Information on relay pin configuration of specific channel (see *Channel type* in *Main Page*)
- **Initial Channel State** – idle state of the channel after startup (*Open / Close / PowerOn / PowerOff*) Depending on configuration used (see chapter **Device versions**).
- **Reboot Channel State** – Channel state when in Reset state (opposite to the *Initial Channel State* value).

Reset by Ping – Incoming Ping

- **IP range** – range of IP addresses given by **IP address** and **network mask**, which PING will be accepted from.
- **Timeout for reboot** – interval, that *IP WatchDog* waits for incoming PING from the monitored device before causing Reset. This interval can be from the range of 0-1800 seconds, where 0 means disabling the function.

Reset by Ping – Outgoing Ping

- **Primary target IP** – IP address of the target device.
- **Secondary target IP** – secondary IP address of the target device. In case of monitoring a single device (IP), both primary and secondary address will be the same.
- **Pinging Timeout**– interval between individual sent pings from the range of 0-1800 seconds. "0" value = function disabled.
- **Failed pings per timeout for reboot**– Number of allowed sent PINGs without response from the *IP WatchDog* during a *Pinging Timeout* interval

Note: *Interval between the individual pings (attempts) = Pinging Timeout / Failed pings per timeout for reboot.* => Which implies :

- *Minimal interval between possible resets = Pinging Timeout*
- *Maximal number of the invalid pings allowed = Failed pings per timeout for reboot*

Monitoring by HTML page – HTML page (TCP Server)

- **Request Page** – http address of the WWW page which must be requested from the IP WatchDog to prevent Reset.
- **Device IP** – IP address that can send a valid request for a WWW page to reset the timer.
- **Timeout for reboot** – interval, that IP Watchdog waits for the request for the WWW page before causing Reset. Interval can be from the range of 0 -1800 seconds, where 0 value stands for disabled function.

Monitoring by HTML page – WWW page Request (TCP Client)

- **Server IP** – IP address of the server which the request for WWW page will be addressed to.
- **Address of HTML page on the server** – name of required file (e.g. index.html, index.htm, default.html etc.), file must be saved in a root directory of the server.
- **Actual address of HTML page on the server** – complete file address allowing fast address verification-
- **Timeout for reboot** – interval, that *IP WatchDog* waits for a WWW page before causing Reset. This parameter must be set in consideration of the speed of the transfer line and server loading. Interval can be set from the range of 0 -1800 seconds, where 0 stands for disabled function.
- **Failed attempts to read HTML page** – Number of allowed failed attempts to read HTML page before Reset.

Monitoring by RS-232 String

- **Timeout for reboot** – interval, that *IP WatchDog* waits for a string on the appropriate RS-232 port before causing Reset. Interval can be set from range of 0-1800 seconds where 0 represents disabled function.
- **Incoming string inside incoming HTML page** – sets a string that will be considered as a prove of device activity. The string can be defined in HEX, DEC or ASCII format. Combining HEX, DEC and ASCII chars can be achieved using prefixes:
 - **#** - for HEX characters;
 - **\$** - for DEC characters;
 - **<string>** - for ASCII characters.

*Note: It is also possible to use alternative symbols: ? for any individual character and * for any character string – for example, if you set string IP_WTD – string like * IP_WTD #10#13 will be accepted.*

IP WatchDog Setup Page

IP WatchDog Setup Page contains two groups of configuration parameters: **Global** and **Time and Date**.

IP-WatchDog Setup Page - Firefox

Soubor Úpravy Zobrazení Efekt Záznamy Nástroje Nápověda

http://192.168.5.60/cgi-bin/setup/setup.cgi

Main Page - Channel 1 Admin Page - Channel 2 Admin Page - SetupPage - UploadFirmware

IP-WatchDog

IP-WatchDog Setup Page

IP WatchDog Global

Current Network settings	IP address:	192.168.5.60
	Mask:	255.255.255.0
	GateWay:	192.168.5.1
	DHCP:	Disabled
RS232 speed (baudrate) <small>For incoming RS232 reset (not by RS232-setup).</small>	9600	,0,N,1
Main Page Refresh time <small>Set refresh time for the IndexPage. (0 = refresh disabled).</small>	10	s

Save values

Time and Date

Time	23:21:07	(HH:MM:SS)
Date	17/07/2005	(DD/MM/YYYY)
Time server IP address	192.43.244.18	
Time server protocol (If you have problems with time synchronization, check the IP-WatchDog's preset gateway and connection to the time server through your router).	<input checked="" type="radio"/> NTP (Time zone required) <input type="radio"/> Time <input type="radio"/> Daytime	
IP-WatchDog: time zone <small>Set the local time zone shift(+ or -) by comparison with UTC.</small>	+1:00:00	<small>Time is formatted by this example: +HH:MM:SS or HH:MM:SS for positive shift -HH:MM:SS for negative shift</small>

Refresh time now Save values

Hotovo

IP WatchDog Global

- **Current Network settings** – Actual device's network parameter configuration. If the DHCP server is allowed to assign them (*DHCP enabled*), the gained values are then damped.
 - **IP address** – actual device's IP address
 - **Mask** – actual network mask
 - **Gateway** – actual Gateway
 - **DHCP enabled/disabled** – information whether assigning of the network parameters by DHCP server is enabled
- **RS232 speed (baudrate)** – baudrate configuration of RS-232 ports – required for receiving valid strings when monitoring the serial channel.
- **Main Page Refresh time** – *Main Page* refresh rate.

Time and Date

- **Time** – shows actual time in HH:MM:SS format that can be set in *IP WatchDog*.
- **Date** – shows actual date in DD/MM/YYYY format that can be set in *IP WatchDog*.
- **Time server IP address** – server IP address, which *IP WatchDog* will be synchronized with.
- **Time server protocol** - protocol for time synchronization. If the server is not located within internal network, proper router or firewall communication ports must be also enabled for this server.
 - **NTP** – most common time synchronization protocols (UDP port 123). Requires filling of the following *IP-WatchDog* fields: *time zone* and *Time server: time zone*.
 - **Time** – older but easy protocol (UDP port 37).
 - **DayTime** – not very common protocol that is implemented in Windows (TCP/UDP port13).
- **IP-WatchDog: time zone** – time zone according to GMT in the +/- HH:MM:SS format, where *IP WatchDog* is located.
- **Refresh Time now** – button for immediate time synchronization.

IP WatchDog – File Upload

IP WatchDog – File upload is a page for easy firmware update over www interface. Consists of two lines and two buttons:

- **Current version** – displays actual firmware version
- **Browse** – allows easy search for the proper HWG firmware file.
- **Upload** – performs upload of the firmware to *IP WatchDog*

Note:

- When firmware is uploaded the *IP WatchDog* will be automatically rebooted.
- Page is accessible ONLY via **IP-WatchDog Setup Page**

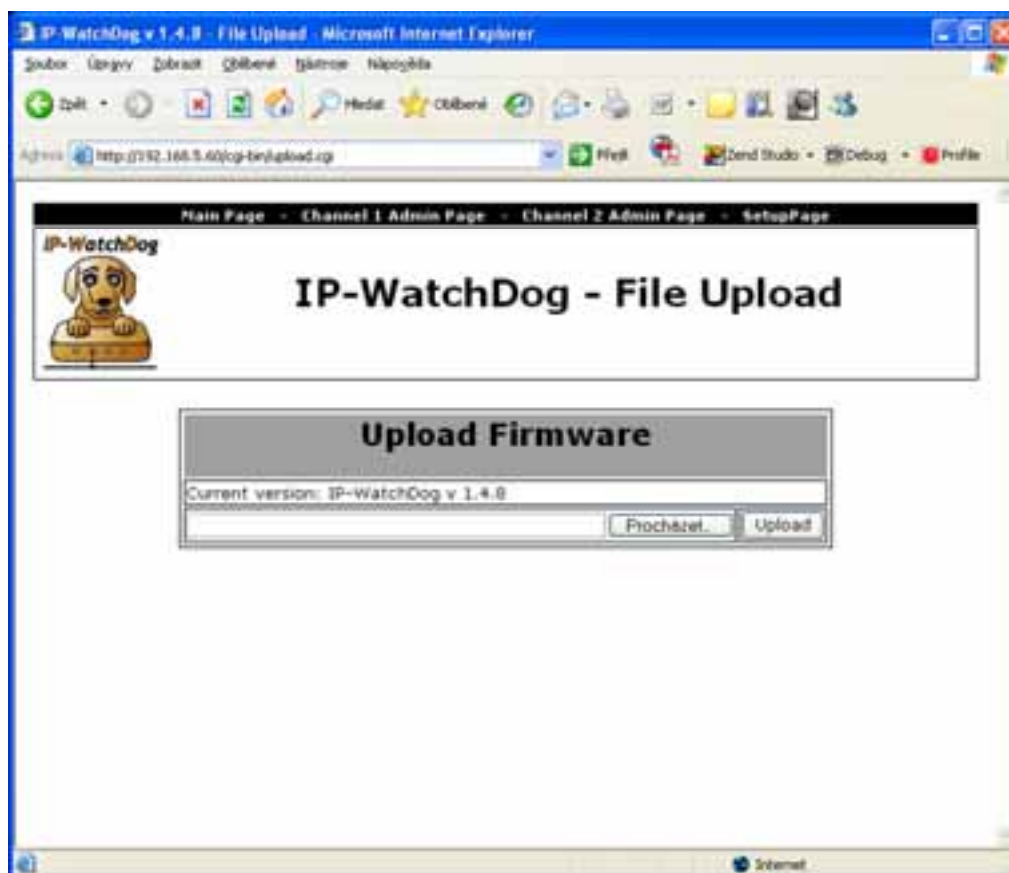

Description of configuration parameters

In the following chapter you will find a detailed description of all configuration parameters used for device settings, which can be realized by serial or TCP terminal. Information on connection to Serial or TCP Setup can be found in the chapter „*Quick Setup*“.

Device's default configuration

Bellow you can find the list of standard configuration of any supplied *IP WatchDog*. The default configuration can be set anytime by choosing option “D0” or “D1” from Setup. Description of device configuration and command entering can be found in chapter “*Quick Setup*”.

```
=====
*** IP-WatchDog - version 1.9.8 - Jul  2 2006 20:26:29 ***
=====
ActualTime: 18:53:26 ActualDate: 26/7/2006
Time is synchronized with: NTP Server[192.43.244.18]
=====
MAC Address                00:0A:59:01:E0:03
===== IP Setup =====
I: IP address              192.168.1.60
M: Mask                    255.255.255.0
G: Gateway                 192.168.1.1
B: DHCP configuration      OFF
===== In IP access WEB filter =====
W: IP address              0.0.0.0
N: Mask                    0.0.0.0
===== Security Setup =====
%S: Remote setup          UDP & TCP(Port:99)
@R: Periodic Reboot 1440
===== WebPage-Security Setup =====
$N: Authorization username (not set)
$P: Authorization password *****
===== Other =====
D: Load Settings from EEPROM
R: Reboot
X: Exit
L: XML log
WatchDog>
```

Device's network parameters

===== IP Setup =====

IP WatchDog's IP address

I: IP address 192.168.6.19

Entry example: I192.168.6.4

Sets IP WatchDog's IP address.

Network Mask

M: Mask 255.255.255.0

Entry example: M255.255.255.0

Configuration of local network IP mask. The IP relay will communicate via Gateway with all IP addresses except those defined by Mask and own IP address.

Default Gateway

G: Gateway 192.168.6.1

Entry example: G192.168.6.1

Gateway address, which grants device an access to external networks. Except for the IP addresses defined by configured IP address and Mask.

Enabling automatic configuration by DHCP server

B: DHCP configuration OFF

Possible options: 0 / 1 (0 – disabled, 1 - enabled)

Entry example: B1

DHCP server allows automatic device configuration without need of any user's actions. IP address, network mask and default gateway parameters can be assigned. Because DHCP assigns IP address that is available at the moment, it does not have to be always the same.

MASK, IP address and Gateway description:

Ethernet device communicates:

- **Within local Ethernet.** You don't need a Gateway, but IP addresses of both devices must be in the range allowed by the Mask setting. If you set the Mask to 255.255.255.0 it means that IP addresses may differ only in the last byte of the IP address.
- **Outside the local network – via Gateway,** which is located in the range or IP addresses allowed by the mask.

You can also restrict the range of IP addresses that the device will not communicate with. This can be set using „In IP Setup“. For debugging purposes we recommend keeping this parameter at 0.0.0.0.

Securing by restricting the range of IP addresses

===== In IP access filter =====

IP address for remote configuration

W: IP address 0.0.0.0

Entry example: G192.168.6.1

IP address of the network or computer, which can establish the connection with the device. After bit multiplication of the opposite IP address by restrictive Mask (N option) you can gain the address mentioned here. Otherwise the device will not react.

Mask for remote configuration

N: Mask 0.0.0.0

Entry example: G192.168.6.1

Mask restricting access addresses, which can establish communication with the device. With the help of this mask you have a higher chance to prevent a security break or avoid unwanted communication with unauthorized device.

Leaving the Setup mode

X: Exit

Entry example: x

Allows to exit the Setup temporarily and to run the IP WatchDog in the operational mode even at closed **DIP1**. If the DIP1 is closed at next WatchDog's startup as well, the device will already enter the Setup mode.

XML log

L: XML log

Example: L

Makes the system log available through an XML format.

Application hints

Security

Access to the configuration WWW page - *Channel Admin Page* and *Setup Page* can be also restricted by user name and password, which can be defined in the serial / TCP Setup. If user name or password has been set, it is required for every access to these pages and for every manual reset using the *Manual Reboot* button of the *Main Page*. This precaution can be deactivated by sending an empty user name and password (default state).

Advanced security provides DIP3, which, if activated, requires user name and password authorization even for access to serial / TCP Setup. When DIP3 is closed the UDP Setup is deactivated, because it would allow changing the network parameters easily, even for beginner.

Reboot Hold Time

Besides the classic reset of the monitored device and its following release, the *IP WatchDog* allows also the possibility of permanent Reset state in case the monitored device does not respond to the WatchDog's requests or does not send regular refresh impulses. This mode can be activated by setting the *Reboot Hold Time* parameter to "0". If the RESET state is called in this mode, the channel (or its output) remains in this state until the monitored device reports itself again or the channel is deactivated.

The function is suitable for cases when *IP WatchDog* does not reset directly monitored device or when one of the channels serves for activation of the backup device or other alarm system.

Note: *If the value of the Reboot Hold Time = 0, the WatchDog enters the Permanent Reboot Hold Time mode where the Reset function and especially Manual Reset behave the different way than in the standard mode that were described above. This Reset state can't be ended by itself. Especially using Manual Reset with deactivated channel when there is no way to end the Reset state and only possibility is to activate the channel and initialize the refresh impulse.*

Time protocol

The Time protocol consists in the server listening on the port 37 and after establishing connection it (using the TCP or UDP protocol) sends user a 32bit number with a mark (in a binary supplement format). The number represents the number of seconds since 00:00:00 of the January 1, 1900 GMT. The number 2.398.291.200 therefore corresponds to 00:00:00 of the January 1, 1976 GMT and number - 1.297.728.000 corresponds to 00:00:00 of the November 17, 1858 GMT. If the server does not support this function the connection will be either refused or closed immediately. The time synchronization accuracy using this protocol is not very high and lies around 1 second. Detailed description of the Time protocol can be found in **RFC-868** document.

NTP

Network Time Protocol (port 123 UDP, for tracing it's also TCP), which also uses 64bit time mark in the number format with fixed base point, is much more sophisticated than Time protocol and more accurate as well. It's intended for permanent time synchronization of more computers on network. The NTP protocol is based on the fact, it doesn't try to synchronize the computer times mutually (that means it does not "average out" the times), but the time is synchronized in comparison with the UTC time ("Universal Time Coordinated").

The synchronized servers are thus placed into hierarchical multi-level tree structure. Thanks to this the load can be poised and the NTP service can be distributed according to the user's needs. In the top layer there are main time devices (atomic clock, GPS, clock set by a time signal, etc.) Each server is in a specific layer (stratum), while the first layer (stratum-1) represents the server that is connected to some external time device (stratum-0). Its "descendants" (e.g. in second, third or fourth layer) are assumed to be less accurate.

The synchronization accuracy lays in tenths of milliseconds. The main transfer protocol UDP. The NTP protocol description can be found in the RFC-1305 document.

SNTP

The SNTP (Simple Network Time Protocol) is based on the NTP (Network Time Protocol) and for communication it uses port 123 as well. Main difference makes the client, which only supports SNTP, cannot serve as a server for other clients, allows time synchronization by one server only and has lower synchronization accuracy. The synchronization accuracy of this protocol lays from units to tenths of milliseconds which is sufficient for common usage. Detailed description of the SNTP protocol can be found in the [RFC-2030](#) document.

Using IP WatchDog in P2P networks

In case you use the IP WatchDog in the environment of the Peer-to-Peer networks, such as DC++, Kazz, Bittorent etc, there might occur flooding of the IP WatchDog's network interface, caused by a large amount of residual packets which can cause the false restarts of the monitored devices. Then it is recommended to lower the @R parameter in TCP Setup to circa 60 (according to the monitoring period). The value gives the number of minutes between individual restart of the IP WatchDog.

Monitored devices WILL NOT be restarted.

Master Reset

In case the TCP Setup or WWW becomes blocked by either wrong configuration or erroneous Firmware upload, the Master Reset can be executed. This will restore the default factory configuration.

Warning : Executing Master Reset will cause that all the user's settings including IP and passwords will be lost!

Procedure of the Master Reset:

- Disconnect the power from the IP WatchDog Lite
- Turn the power on.
- During first 5 seconds since power-on change the DIP1 position to the second position and then back again.
- Wait for circa 30 seconds. The IP WatchDog Lite default configuration will be restored.

Testing and operation hints for Windows and Linux

Testing the function of Incoming Ping

Testing command of the Incoming Ping function for Windows

Application of the ICMP PING function in Windows is very simple but can be even little tricky. Main ping testing can be managed via Windows command line (START menu -> Run -> enter "cmd" and press OK). Command line application will appear (in older Windows versions it is MS-DOS window). In that just enter the command in following format:

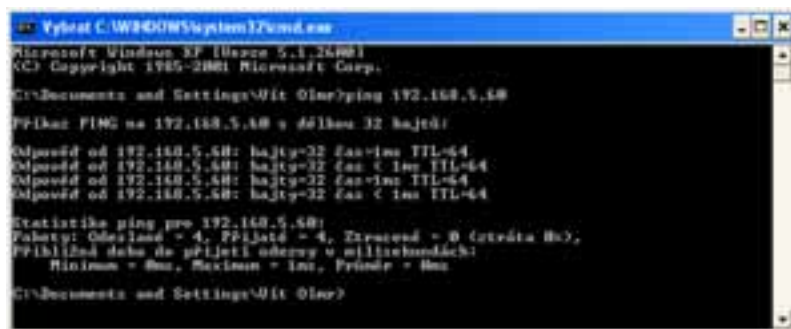

```
Microsoft Windows XP [Verze 5.1.2600]
(C) Copyright 1985-2001 Microsoft Corp.

C:\Documents and Settings\Vit Olmr>ping 192.168.5.60

Přikaz PING na 192.168.5.60 s délkou 32 bajtů:

Odpověď od 192.168.5.60: bajty=32 čas=1ms TTL=64
Odpověď od 192.168.5.60: bajty=32 čas < 1ms TTL=64
Odpověď od 192.168.5.60: bajty=32 čas=1ms TTL=64
Odpověď od 192.168.5.60: bajty=32 čas < 1ms TTL=64

Statistika ping pro 192.168.5.60:
Pakety: Odeslané = 4, Přijaté = 4, Ztracené = 0 (ztráta 0%),
Přibližná doba do přijetí odezvy v milisekundách:
Minimum = 0ms, Maximum = 1ms, Průměr = 0ms

C:\Documents and Settings\Vit Olmr>
```

ping ip_adresa_watchdogu, například **ping 192.168.5.60**

You will get similar screen like this:

```
Microsoft Windows XP [Verze 5.1.2600]
(C) Copyright 1985-2001 Microsoft Corp.

C:\Documents and Settings\Vit Olmr>ping 192.168.5.60

Přikaz PING na 192.168.5.60 s délkou 32 bajtů:

Odpověď od 192.168.5.60: bajty=32 čas=1ms TTL=64
Odpověď od 192.168.5.60: bajty=32 čas < 1ms TTL=64
Odpověď od 192.168.5.60: bajty=32 čas=1ms TTL=64
Odpověď od 192.168.5.60: bajty=32 čas < 1ms TTL=64

Statistika ping pro 192.168.5.60:
Pakety: Odeslané = 4, Přijaté = 4, Ztracené = 0 (ztráta 0%),
Přibližná doba do přijetí odezvy v milisekundách:
Minimum = 0ms, Maximum = 1ms, Průměr = 0ms
```

If you wish to send the PING permanently, enter the command with the **-t** parameter: :

ping 192.168.5.60 -t

Command line can be also launched using the standard windows shortcuts, that can be located in the program menu:

- **Windows 98:** Start | Programs | MS-DOS Prompt
- **Windows NT:** Start | Programs | Command Prompt
- **Windows ME:** Start | Programs | Accessories | MS-DOS Prompt
- **Windows 2000:** Start | Programs | Accessories | Command Prompt

Problems in using PING under Windows can appear when using Firewall or have Windows XP with SP2 (service pack), that already contains a simple firewall. So if you are unable to use PING to the Watchdog or from it, check that the firewall configuration does not block ICMP commands *echo reply* and *echo request* (if it does, unblock them) or use other method (like WWW page). Some servers themselves block the PING commands to prevent overloading and "pinging to death" (so called Ping of Death attack).

Test command for Incoming Ping under Linux/Unix

Using PING command under Unix and Linux OS is as simple as in the case of Windows, maybe even easier because you don't have to run the command line. Just enter the following into the console:

```
ping 192.168.5.60
```

Operational command of the function Incoming Ping under Windows

Windows provide a free service for Windows Server 2000/2003 and Windows 2000/XP, that can be downloaded from

http://www.hw-group.com/download/IPWDT_Setup_1.0.zip

allowing sending ping to the defined address in regular intervals. The form of *services* is applied to allow running it automatically even on server systems without a need of logging in. After Unpacking and installation it is necessary to modify a configuration file **IPWDT.ini**, that can be located at **C:\Program Files\HW group\VPWD Tools**.

It contains following:

```
[PING]
IP=192.168.1.9
INTERVAL=10
DEBUG=2
```

Interval is measured in seconds, Debug parameter defines whether the communication will be logged in the directory **C:\Program Files\HW group\VPWD Tools** (max. file size is 5MB).

An icon for **IP WatchDog Tools Control** created in Control panel allows activation and deactivation of the services



Operational command for Incoming Ping under Linux/Unix

In Unix systems it is used so called demon cron, that executes commands according to the crontab, that is a simple text document that contains data in a tab in following format:

1	2	3	4	5	6	7
* / 1	*	*	*	*	user's account	command

Where :

1. minute
2. hour
3. day of a month
4. month
5. day of a week (0 - Sunday, 1 - Monday... 6 - Saturday)
6. user's account
7. path to the program or command that should be executed

This tab can be edited easily using a command `crontab -e`, that opens the specific document. The created entry can look like this :

* / 1	*	*	*	*	root	ping 192.168.5.60
-------	---	---	---	---	------	-------------------

This command will execute the ping every minute.

Testing the Outgoing HTML Page function

Testing the Outgoing HTML Page function

For the primary test of this function it is possible to use an online form, that can be found at http://www.hwg.cz/products/ip_watchdog/test/test_outgoing_page.html

Just enter IP address of the IP Watchdog, port where it listens. In fact IP WatchDog always listens at port 80, but in case there is a lack of the public IP, it is possible to use address translation (NAT – network address translation). Then enter your public IP address and port number configured in the NAT.

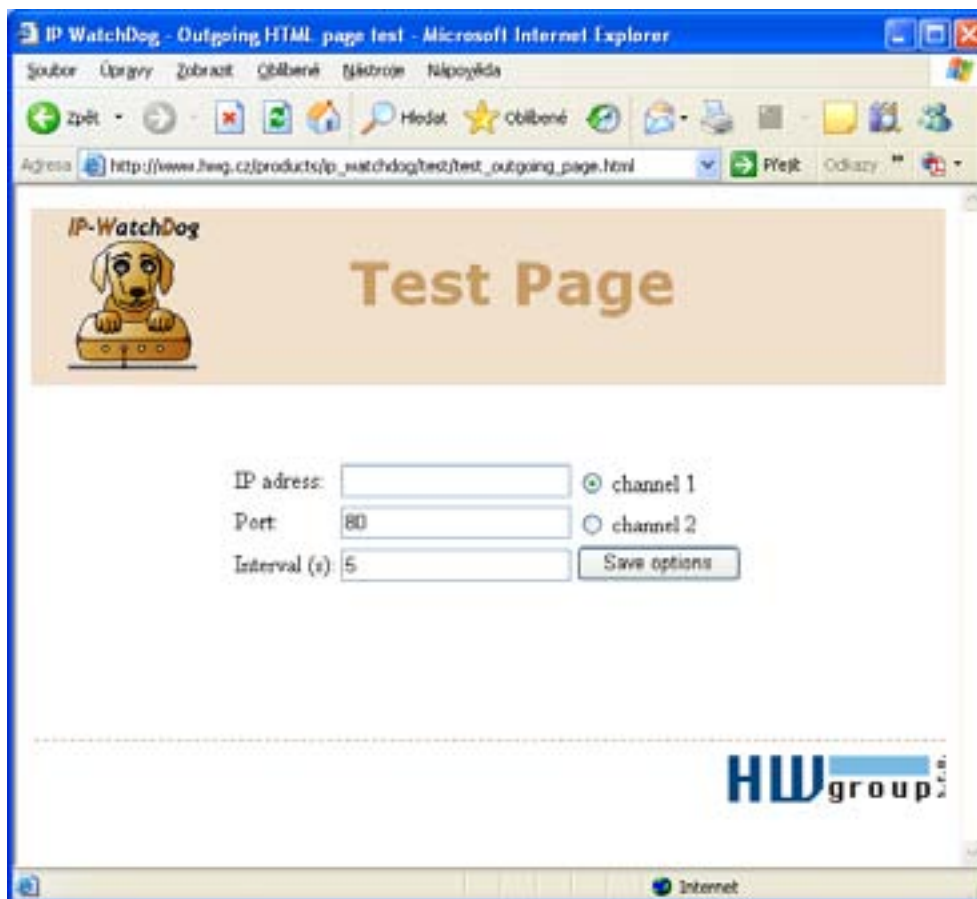

Operational command Outgoing HTML Page under Linux/Unix

Unlike Windows, the Unix systems again provide a popular cron, while in the command position we will use function **wget** – `wget http://192.168.0.1/index.html`

Example :

```
*/1 * * * * root wget http://192.168.0.1/index.html
```

This will execute ping every minute.

Mechanical dimensions

The device is situated in a sturdy metal box. According to the ordered version of the device you can choose the “L” plate for wall mounting or removable brackets for a DIN molding.

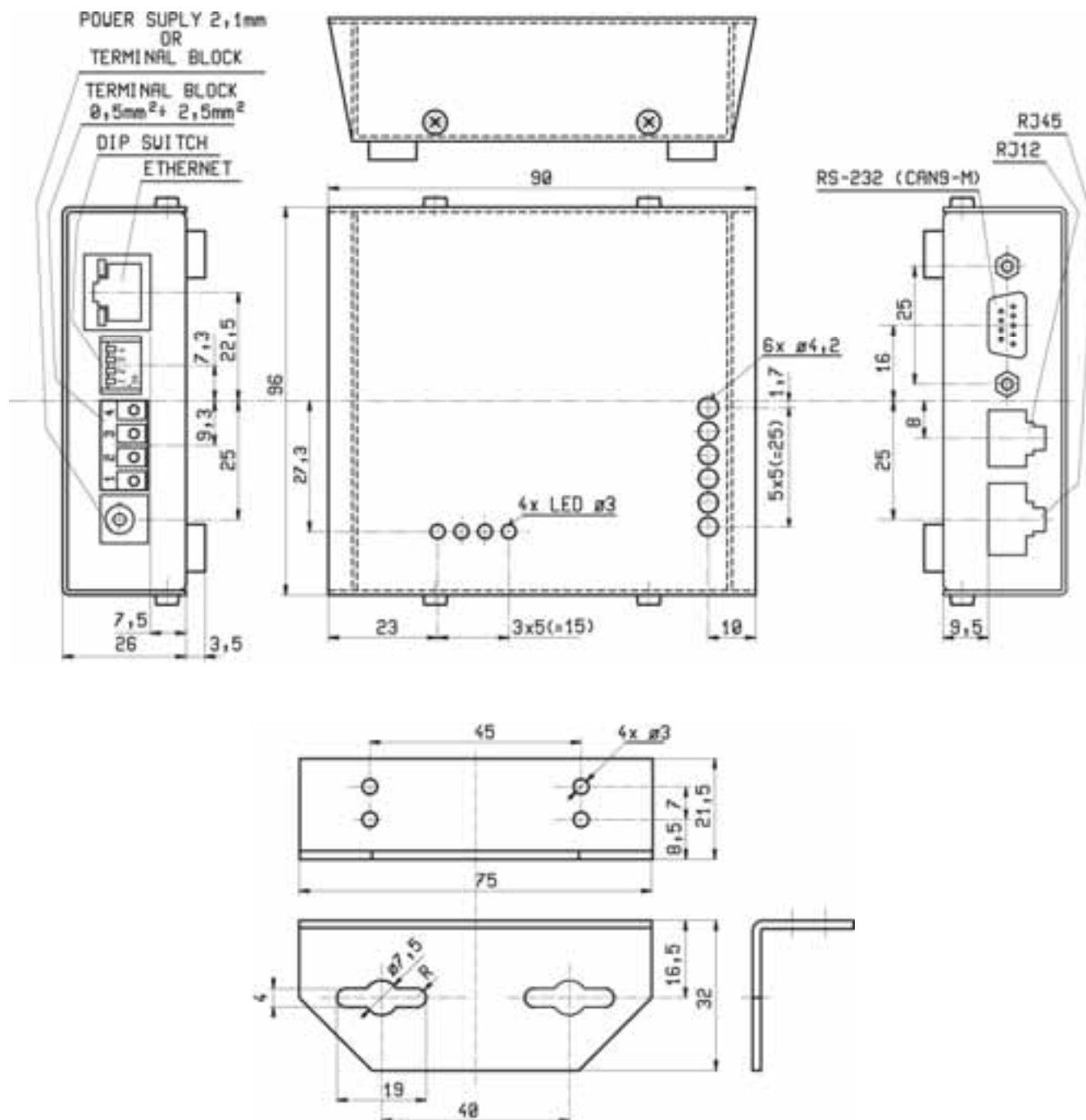

- By standard, the box contains a rubber “stands”.
- It is possible to order removable mounting for a DIN molding, which is to be attached from below, in the middle of the plate or
- Two metal “L” profiles for wall mounting.

For the descriptions of the variations that can be ordered see the end of this manual.

Device versions

IP WatchDog can be supplied in several versions differing in relay's contact configuration (see the figure below).

Ordering Nr.	Product name	Device version
600 007	IP WatchDog PO/NO	Channel 1 = PO, Channel2 = NO
600 008	IP WatchDog PF/NO	Channel1 = PF, Channel2 = NO
600 009	IP WatchDog NO/NO	Channel1 = NO, Channel2 = NO
600 010	IP WatchDog NC/NO	Channel1 = NC, Channel2 = NO
600 011	IP WatchDog PO/NC	Channel1 = PO, Channel2 = NC
600 012	IP WatchDog PF/NC	Channel1 = PF, Channel2 = NC
600 013	IP WatchDog NO/NC	Channel1 = NO, Channel2 = NC
600 014	IP WatchDog NC/NC	Channel1 = NC, Channel2 = NC
600 015	IP WatchDog PO/PO	Channel1 = PO, Channel2 = PO
600 016	IP WatchDog PF/PO	Channel1 = PF, Channel2 = PO
600 017	IP WatchDog NO/PO	Channel1 = NO, Channel2 = PO
600 018	IP WatchDog NC/PO	Channel1 = NC, Channel2 = PO
600 019	IP WatchDog PO/PF	Channel1 = PO, Channel2 = PF
600 020	IP WatchDog PF/PF	Channel1 = PF, Channel2 = PF
600 021	IP WatchDog NO/PF	Channel1 = NO, Channel2 = PF
600 022	IP WatchDog NC/PF	Channel1 = NC, Channel2 = PF

PO (Power On) - contacts A and B: when started the external supply voltage lead out over (A = +, B = GND) breaking contact (closed on startup).

PF (Power Off) - contacts A and B: when turned on, the A and B terminals without power (A = +, B = GND); switching contact (open on startup).

NO (normally open) - contacts A and B: switching contact is lead out. When the power supply is turned on it's open.

NC (normally close) - contacts A and B: break contact is lead out. When the power supply is turned on it's closed.

Optional accessories and related products

Ordering Nr.	Product name	Description
600 023	2x L profile "A" size	2 "L" profiels for screw mounting
600 025	DIN Rail box set	Including instalation on the box
600 084	DIN Rail Relay - 1x switch contact 10 A	Unipolar 12V relay with switching contact on the DIN molding, allowing closing the voltage directly up to 250V/10A.
600 085	DIN Rail Relay - 2x switch contact 10 A	Unipolar 12V relay with switching contact on the DIN molding, allowing closing the voltage directly up to 250V/10A.
600216	DB9M / 2x RS-232 Rx converter	Converter for connection of two RS-232 (DB9M) IP WatchDog (1x DB9M - Ch1- RxD; Ch2 - CTS)



600 023 – 2x L profile "A" size



600 216 – DB9M / 2x RS-232 Rx converter



600 025 – DIN Rail box set



600 085 – DIN Rail Relay - 2x switch contact 10 A



600 084 – DIN Rail Relay - 1x switch contact 10 A

Contact

HW group or HW server

U Pily 103/3
143 00 Prague4
Czech Republic

Tel. +420 222 511 918

Fax. +420 222 513 833

<http://www.HWgroup.cz/>

