

# EZL-400S User's Manual

Version 1.1



Sollae Systems Inc.

-Table of Context -

<b>1. OVERVIEW</b> .....	<b>- 4 -</b>
1.1. OVERVIEW .....	- 4 -
1.2. COMPONENTS.....	- 5 -
1.3. SPECIFICATIONS .....	- 5 -
1.3.1. <i>Power</i> .....	- 6 -
1.3.2. <i>Dsub Connector</i> .....	- 6 -
1.3.3. <i>Network Interface</i> .....	- 7 -
1.3.4. <i>LED Interface</i> .....	- 7 -
1.3.5. <i>Console S/W</i> .....	- 8 -
<b>2. INSTALLATION AND TEST RUN</b> .....	<b>- 9 -</b>
2.1. INSTALLATION METHOD.....	- 9 -
2.1.1. <i>Checking the Communication Environment</i> .....	- 9 -
2.1.2. <i>Connecting to the Network</i> .....	- 10 -
2.1.3. <i>Configuring the Environmental Variables</i> .....	- 10 -
2.2. TEST RUN.....	- 10 -
2.2.1. <i>Changing PC IP Address</i> .....	- 10 -
2.2.2. <i>Installing EZL-400S</i> .....	- 10 -
2.2.3. <i>Connecting to Serial Port of PC</i> .....	- 10 -
2.2.4. <i>Communication Test</i> .....	- 11 -
<b>3. CONFIGURING ENVIRONMENTAL VARIABLES</b> .....	<b>- 12 -</b>
3.1. CONFIGURATION WITH EZCFGMP .....	- 12 -
3.1.1. <i>Local Search</i> .....	- 12 -
3.1.2. <i>Remote Search</i> .....	- 13 -
3.1.3. <i>The differences between LOCAL SEARCH and REMOTE SEARCH</i> .....	- 14 -
3.1.4. <i>Configuring with ezcfgmp</i> .....	- 14 -
3.2. CONFIGURATION BY CONSOLE .....	- 19 -
3.2.1. <i>Entering the Console of EZL-400S</i> .....	- 19 -
3.2.2. <i>Menu Structure</i> .....	- 20 -
<b>4. THE OPERATION MODE OF EZL-400S</b> .....	<b>- 22 -</b>
4.1. NORMAL COMMUNICATION MODE .....	- 22 -
4.2. CONSOLE MODE.....	- 22 -
<b>5. NORMAL COMMUNICATION MODE</b> .....	<b>- 23 -</b>

5.1.	T2S .....	- 23 -
5.1.1.	<i>Communication</i> .....	- 23 -
5.1.2.	<i>Connection Termination and Keep Alive Function</i> .....	- 23 -
5.2.	ATC .....	- 24 -
5.3.	COD .....	- 25 -
5.3.1.	<i>Communication</i> .....	- 25 -
5.3.2.	<i>Connection Termination and Keep Alive Function</i> .....	- 25 -
5.3.3.	<i>Reconnection</i> .....	- 25 -
5.4.	U2S.....	- 26 -
<b>6.</b>	<b>ATC MODE .....</b>	<b>- 27 -</b>
6.1.	OVERVIEW .....	- 27 -
6.1.1.	<i>AT command format</i> .....	- 27 -
6.2.	BASIC AT COMMAND SET (EXAMPLE: ATA, ATD ETC.) .....	- 27 -
6.3.	EXTENDED AT COMMANDS (EXAMPLE: AT+PLIP ETC.) .....	- 28 -
6.4.	ONLINE STATE AND ONLINE COMMAND STATE .....	- 28 -
6.4.1.	<i>Changing Online State to Online Command State</i> .....	- 28 -
6.4.2.	<i>Changing Online Command State to Online State</i> .....	- 28 -
6.5.	EXAMPLE OF TCP CONNECTION .....	- 29 -
6.5.1.	<i>Example of Active Connection</i> .....	- 29 -
6.5.2.	<i>Example of passive Connection</i> .....	- 29 -
6.6.	EXAMPLE OF TCP DISCONNECTION .....	- 29 -
6.6.1.	<i>Example of active disconnection</i> .....	- 29 -
6.6.2.	<i>Example of passive disconnection</i> .....	- 30 -
<b>7.</b>	<b>TECHNICAL SUPPORT, WARRANTY, AND NOTES ON OPERATION.....</b>	<b>- 31 -</b>
7.1.	TECHNICAL SUPPORT .....	- 31 -
7.2.	WARRANTY .....	- 31 -
7.2.1.	<i>Refund</i> .....	- 31 -
7.2.2.	<i>Free Repair Services</i> .....	- 31 -
7.2.3.	<i>Charged Repair Services</i> .....	- 31 -
7.2.4.	<i>Notes on Operation</i> .....	- 31 -
<b>8.</b>	<b>REVISION HISTORY .....</b>	<b>- 33 -</b>

---

# 1. Overview

## 1.1. Overview

Along with the development of the Internet, the demand for data communication functions has increased recently. Data communication over the Internet requires using TCP/IP, the Internet communication protocol. That is to say, in order to connect a system to the Internet, TCP/IP protocol must be implemented. It is possible to implement TCP/IP by directly implementing the protocol, porting public TCP/IP, or using Operating System (OS). However, all these methods impose burdens on the developer in time, cost, and technology.

ezTCP series, a Serial ↔ TCP/IP protocol converter product group of Sollae Systems, enables you to use TCP/IP communication (the Internet communication) function simply by “connecting the cable to a serial port”. ezTCP sends data from the serial port to the Internet network after TCP/IP processing, and vice versa.

EZL-400S in ezTCP product group is a product that provides TCP/IP communication through wired or wireless LAN. In other words, like other ezTCP products, EZL-400S sends data from the serial port to the wired or wireless LAN after TCP/IP processing and vice versa.

EZL-400S has 4 RS232 ports.

It provides not only DHCP but also PPPoE, so that it can be applied to the cable network and the xDSL network.

As EZL-400S provides SSL security function, it can be used in a system that requires a high level of security.

## 1.2. Components

- EZL-400S Body
- 5V Power Adopter (Option)
- RS232C cable for PC connection (Option)
- PCMCIA Card (Option)

## 1.3. Specifications

Power	Input Voltage	5V ( $\pm 10\%$ )
	Current	500mA typical
Dimension	190mm x 126mm x 29mm	
Weight	About 540g (excluding wireless LAN card)	
Interface	Serial	9pin Dsub male
	Network	10/100Base-TX (without PCMCIA card) IEEE802.11b (with PCMCIA card)
Serial Port	RS232 (1200bps ~ 115200bps)	
Network	IEEE802.11b	
Protocols	TCP, UDP, IP, ICMP, ARP, DHCP, PPPoE, SSL	
Communication Mode	T2S	TCP Server Mode
	COD	TCP Client Mode
	ATC	TCP Server/Client Mode (AT command emulation)
	U2S	UDP
Utilities	ezcfgmp	Configuration Utility via LAN
	ezterm	Socket Test Program
	Hotflash	Firmware download utility via TFTP

☞ You can download free utilities and firmware from <http://www.eztcp.com>.

### 1.3.1. Power

DC 5V is used for EZL-400S and the specification is below:

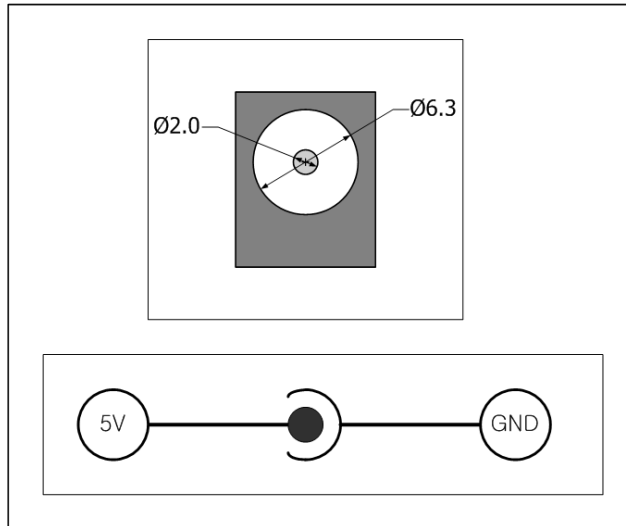

### 1.3.2. Dsub Connector

The connector of serial port is 9 pin Dsub male. The specification is below:

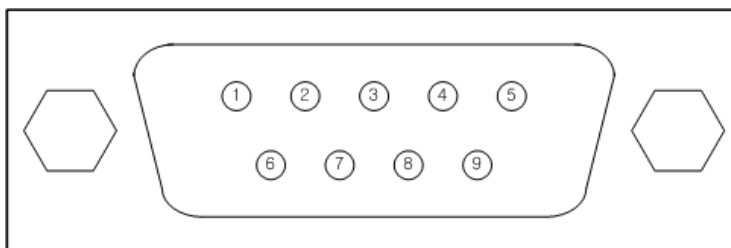

- RS-232

number	name	description	level	Dir.	Etc.
1		NC	-	-	-
2	RXD	Receive Data	RS232	I	Mandatory
3	TXD	Transmit Data	RS232	O	Mandatory
4		NC	-	-	-
5	GND	Ground	Ground	-	Mandatory
6		NC	-	-	-
7	RTS	Request To Send	RS232	O	Optional
8	CTS	Clear To Send	RS232	I	Optional
9		NC	-	-	-

### 1.3.3. Network Interface

The network interface of EZL-400S is composed with Ethernet and wireless LAN. If a wireless LAN card is inserted to EZL-400S, EZL-400S interface is wireless LAN. If there is no wireless LAN card on EZL-400S, EZL-400S interface is Ethernet.

The Ethernet interface has a function that senses whether the network is 10M bit or 100M bit Ethernet automatically. And it has a function that senses whether the cable is cross-over cable or not.(auto MDI/MDIX)

Ethernet devices has there own unique hardware address. EZL-400S also has a hardware address that is set in the factory. (The hardware address is called as MAC address)

EZL-400S requires a PCMCIA 16bit PC card for wireless LAN network. The card should be compliant to PRISM. (If you would use a wireless LAN card which is not provided from Sollae Systems, please test or contact me in advance.)

The MAC address of EZL-400S is in bottom of the body, not in PCMCIA card.

### 1.3.4. LED Interface

Item	Name	Description
	PWR	On when EZL-400S turns on
	RUN	EZL-400S has IP address: blinks once a second EZL-400S hasn't IP address when dynamic IP: blinks 4 times Console mode: blinks every 0.4 second with STS1 in the same time
NET	WLAN	On when linked to wireless LAN
	LAN	On when linked to Ethernet
	TX	Blinks when EZL-400S sends data to the network
	RX	Blinks when EZL-400S receives data from the network
STS	1	On during TCP connection to COM1 Console mode: blinks every 0.4 second with RUN in the same time
	2	On during TCP connection to COM2
	3	On during TCP connection to COM3
	4	On during TCP connection to COM4
Serial	RX1	Blinks when EZL-400S receives data from COM1
	TX1	Blinks when EZL-400S sends data to COM1
	RX2	Blinks when EZL-400S receives data from COM2
	TX2	Blinks when EZL-400S sends data to COM2

	RX3	Blinks when EZL-400S receives data from COM3
	TX3	Blinks when EZL-400S sends data to COM3
	RX4	Blinks when EZL-400S receives data from COM4
	TX4	Blinks when EZL-400S sends data to COM4

### 1.3.5. Console S/W

There is a [CONSOLE S/W] which can be used to change the mode EZL-400S. If user push this button over 1 second, EZL-400S changes its operating mode to the console mode.

## 2. Installation and Test Run

### 2.1. Installation Method

You can install EZL-400S in the following steps.

Title	Item	Sub-item	Description
1. Checking the communication environment	Check items	Network environment	3.1.4.
		Serial port settings	3.1.4.
		Application program to be used	4.
2. Connecting to the network	Check method	Check if LINK LED is ON.	1.3.4.
3. Configuring the environmental variables	Configuration method	Set by ezcfgmp, a utility program for configuration through the network.	3.1.
		Setting in console	3.2.
		By arp (Temporarily set IP address only)	3.1.4.
	Configuration items	IP address related items	3.1.4.
		Serial port related items	3.1.4.
		Communication mode (Decided depending on application program)	5.
4. Application to the field			

#### 2.1.1. Checking the Communication Environment

Before installing EZL-400S, check the network environment where EZL-400S is to be installed, including the followings matters:

- IP address environment (local IP, subnet mask, gateway, etc.)
  - Serial port type of the equipment to which EZL-400S is going to be connected (RS232, RS422, RS485)
  - Serial port items of the equipment to which EZL-400S is going to be connected (baud rate, data bit, parity, stop bit)
  - Application program protocol to be used (TCP/UDP, server/client, SSL, etc.)
- ☞ *For application program protocol to be used, see “5. Normal Communication Mode”.*

### 2.1.2. Connecting to the Network

For wireless LAN, user should configure wireless LAN related items in console mode in advance. After configuring wireless LAN related items of EZL-400S, power EZL-400S on after inserting wireless LAN card. Then EZL-400S will connect to wireless LAN network as user set automatically.

For Ethernet connection, connect EZL-400S to the network without inserting wireless LAN card.

### 2.1.3. Configuring the Environmental Variables

When network connection is completed, configure the environmental variables such as IP address related items, serial port related items, and communication mode related items by `ezcfgmp` or console.

☞ *For environmental variable configuration, see “3. Configuring Environmental Variables.”*

## 2.2. Test Run

You can perform test run according to the following orders. The test run described here is based on the assumption that the IP address of the PC is set to 10.1.0.2 and its network interface is Ethernet.

### 2.2.1. Changing PC IP Address

You can change the IP address of your PC as follows:

IP Address	10.1.0.2
Subnet Mask	255.0.0.0
Gateway IP Address	0.0.0.0

### 2.2.2. Installing EZL-400S

Connect the EZL-400S with the PC through the crossed LAN cable.(When connecting through a hub, use a one-to-one cable for this connection.) If Link LED of the LAN is on, the connection is OK.

### 2.2.3. Connecting to Serial Port of PC

Connect the EZL-400S with the PC through the RS232 cable. And run a serial communication utility – for example: Hyper Terminal or Tera Term Pro. And set the configuration of the utility to [19200bps, 8 data bits, 1 stop bit, no flow-control] as same

as configuration values of EZL-400S.

Then the preparation of test is completed.

#### 2.2.4. Communication Test

When the preparation for serial communication is finished, enter the following in the DOS window on your PC, to connect to TCP through Telnet program.

```
"Telnet 10.1.0.1 1470"
```

Enter "123" on the Telnet window, and "123" will appear on the serial communication utility. Enter "ABC" on the serial communication utility, and "ABC" will appear on the Telnet window. Otherwise, communication test fails.

---

## 3. Configuring Environmental Variables

### 3.1. Configuration with ezcfgmp

The Ezcfgmp is configuration utility of EZL-400S via the network. There are two methods of communication for EZL-400S – LOCAL SEARCH and REMOTE SEARCH. The LOCAL SEARCH method searches EZL-400S in the local network with UDP local broadcast. And the REMOTE SEARCH method searches EZL-400S in any network with IP address if the network is connected to the user's network.

#### 3.1.1. Local Search

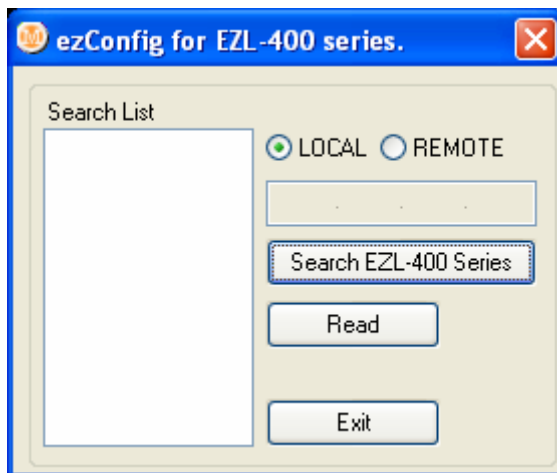

The LOCAL SEARCH method use UDP local broadcast with MAC address. So its benefit is that user can search EZL-400S although the user doesn't know the IP address of EZL-400S. For LOCAL SEARCH, user should select [LOCAL] radio button and press [Search EZL-400 Series]. Then the ezcfgmp searches all EZL-400Ses in the local network. The found EZL-400Ses appear in the [Search List] window in form of its MAC address.

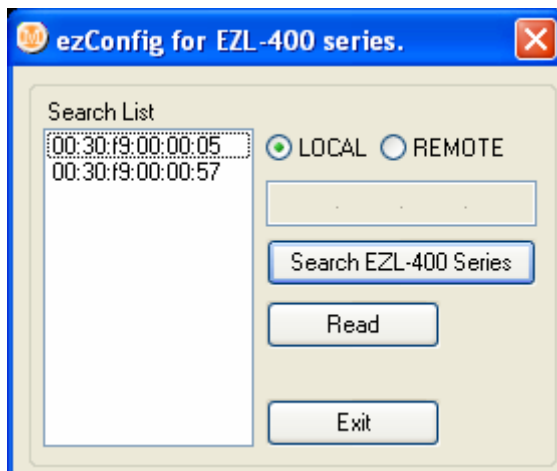

If user clicks the MAC address of among the EZL-400Ses and press [Read] button, the main windows will be appeared.

It is impossible to search EZL-400S outside of the network (router).

### 3.1.2. Remote Search

The REMOTE SEARCH method searches EZL-400S with the IP address. The [Remote Search] item should be activated for this method.

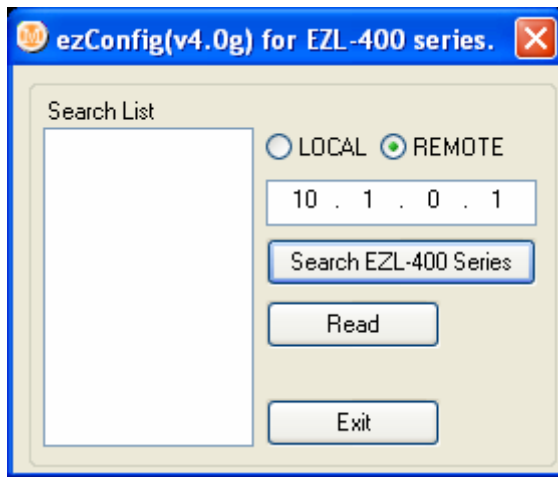

For the REMOTE SEARCH, user should select the [REMOTE] radio button in the initial window and input an IP address and press [Search EZL-400 Series], then the ezcfigmp searches EZL-400S with the IP address.

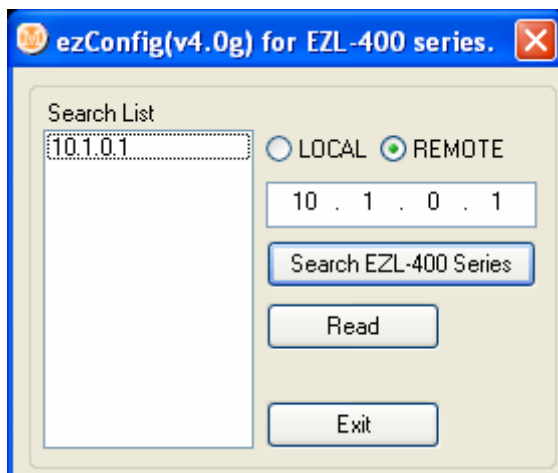

The found EZL-400S is appeared in the [Search List] window. If the user double-clicks the IP address or presses [Read] button, the main window is appeared.

When it doesn't work because of firewall, the user should open UDP 50005 port, because the REMOTE SEARCH of the ezcfigmp uses UDP 50005 port.

### 3.1.3. The differences between LOCAL SEARCH and REMOTE SEARCH

The following table shows the differences between LOCAL SEARCH and REMOTE SEARCH.

	LOCAL SEARCH	REMOTE SEARCH
Communication Method	UDP broadcast	UDP Unicast
Limitation	Inner local network	All regions connected with networks
Differentiation	MAC Address	IP Address
UDP Port Number	Random	50005
Advantage	Possible Searching and Configuration although user doesn't know the IP address	Possible Searching and Configuration if the network is connected
Defect	It can be used in the local network	1. User should know the IP address 2. Firewall problems can be occurred

### 3.1.4. Configuring with ezcfgmp

the following is the main window of the ezcfgmp. User can configure the EZL-400S in the main window more easily.

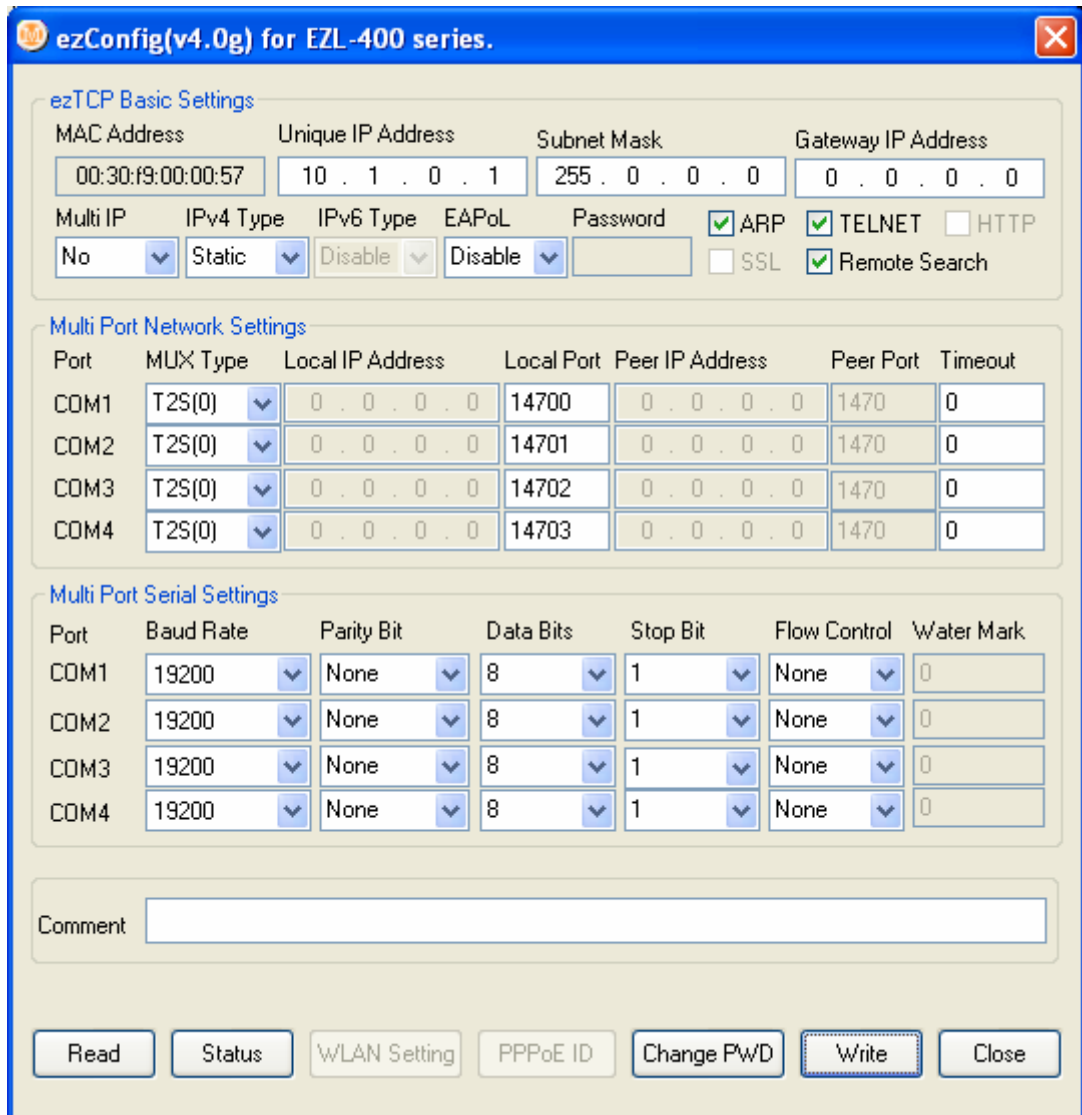

- MAC Address

It is the MAC address of EZL-400S. This value is set in the factory and it cannot be altered.

- Unique IP Address

EZL-400S can use one IP address for four COM ports or the IP addresses can be set to each COM ports differently.

This item is for that EZL-400S uses only one IP address.

The [Multi IP] item is for whether EZL-400S user only one IP address or not.

- Subnet Mask

This item is for subnet mask of the network.

- Gateway IP Address

This item is for the gateway's IP address of the network.

- Multi IP

If this item is set as [Yes], each COM ports can have their own IP addresses. The IP addresses of each COM ports are configured in the [Local IP Address]. In this time, user should set its IP addresses as same subnet mask.

- IPv4 Type

User can select IP address types – static IP, DHCP, and PPPoE.

- IPv6 Type

It is reserved.

- EAPoL

It is for connecting a wireless LAN network that requires EAP authentication.

- Password

Password is used for that user configures EZL-400S with ezcfgmp or logins via telnet client. If EZL-400S is set with a password, user should input the password in this item to configure the EZL-400S.

For changing the password, use [Change PWD].

- ARP

Sets whether to or not to set IP address using ARP protocol. When this item is selected, EZL-400S uses the destination IP address of the first packet coming to its MAC address as its own IP address temporarily.

- TELNET

Only when this item is enabled, you can log in Telnet, to control or monitor EZL-400S through the console.

- HTTP

It is reserved.

- SSL

This item shows whether SSL is enabled or not. But it can't be set with ezcfgmp but console.

- REMOTE Search

To enable a REMOTE SEARCH function, set this item.

- MUX Type

This item is for setting the communication mode of EZL-400S among T2S, ATC, COD, and U2S.

- Local IP Address

If EZL-400S is set as multi IP address, this item is for the IP address of each COM ports. Each IP addresses should be in a same subnet.

- Local Port

It defines local ports of each COM ports.

- Peer IP Address

It defines peer IP addresses of each COM ports.

- Peer Port

It defines peer port of each COM ports.

- Timeout

When EZL-400S operates as TCP such as T2S, COD and ATC, connection is closed if data communication is not continued as long as the time set to this item unless this item is set to 0 (unit: second)

- Baud Rate

It defines the speed of each COM ports.

- Parity

It defines Parity bit of each COM ports.

- Data Bits

It defines the length of Data bits of each COM ports.

- Stop Bit

It defines Stop bit of each COM ports.

- Flow Control

Selects flow control for the serial port (None, RTS/CTS).

- Water Mark

It defines a point of time to start connection when EZL-400S operates as COD. EZL-400S starts to connect to the host (Peer IP Address and Peer Port) of the designated host upon receiving as many data as specified by [Water Mark] bytes from the serial port.

- Comments

It Stores maximum 32 bytes user comment on the product. This item helps the user distinguishes each EZL-400S more easily.

- Read

User can read the environmental variables of EZL-400S by this button.

- Status

User can read current status of EZL-400S by this button for example version, total running time, and IP address, and total communication size.

- WLAN Setting

It is reserved.

- PPPoE, EAPoL ID

It defines ID of PPPoE or EAPoL, if EZL-400S is set as PPPoE or EAPoL.

- Change PWD

User can change the password of EZL-400S with this button.

- Write

User can write the setting values to EZL-400S with this button.

- Close

User can close main window of ezcfgmp.

## 3.2. Configuration by Console

### 3.2.1. Entering the Console of EZL-400S

There are two methods to enter the console of EZL-400S.

- Connecting by telnet

Input data in the command prompt of Windows as follows. The IP address should be the IP address of EZL-400S.

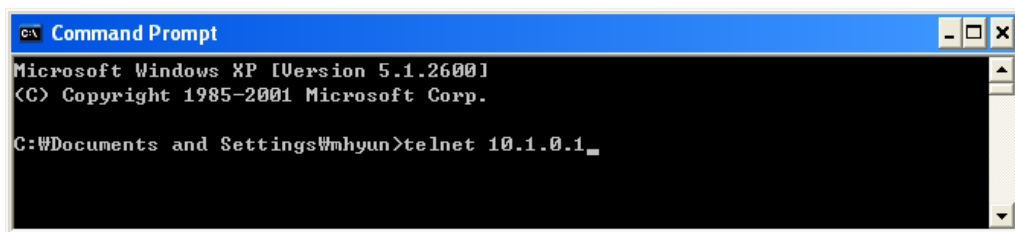

```
Command Prompt
Microsoft Windows XP [Version 5.1.2600]
(C) Copyright 1985-2001 Microsoft Corp.

C:\Documents and Settings\whyun>telnet 10.1.0.1_
```

If the connection is completed, the following message will be shown.

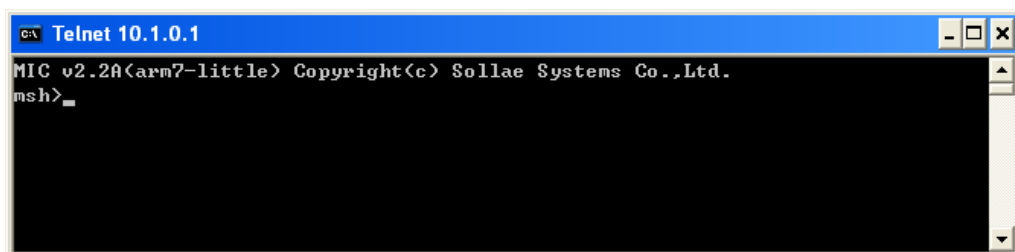

```
Telnet 10.1.0.1
MIC v2.2A(arm7-little) Copyright(c) Solla Systems Co.,Ltd.
msh>
```

The telnet function should be set for telnet login.

- Operating EZL-400S as Console Mode

If user presses a button that is the front side of EZL-400S over 1 second, EZL-400S operates as the Console Mode.

Both the [RUN] LED and the [STS1] LED should blink in the same time in the Console Mode. The COM1 port operates as [19200bps, 8 data bits, 1 stop bit, no parity] in the Console Mode and it outputs messages as followed:

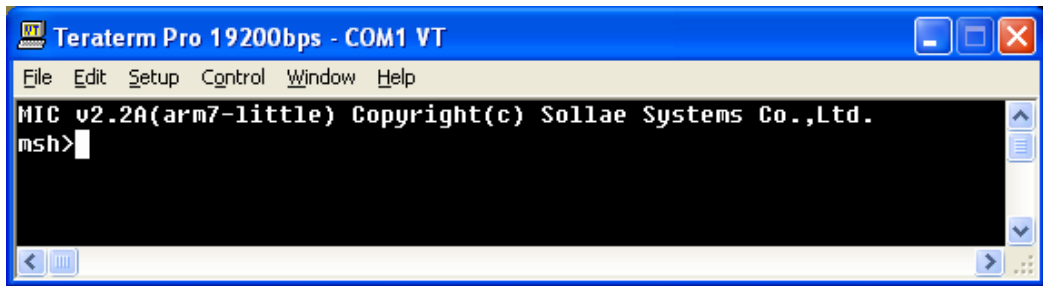

### 3.2.2. Menu Structure

The commands to set the environmental variables of EZL-400S in Console Mode are 'env config' and 'env ext'.

If user inputs 'env config' in the Console Mode, the following will be shown.

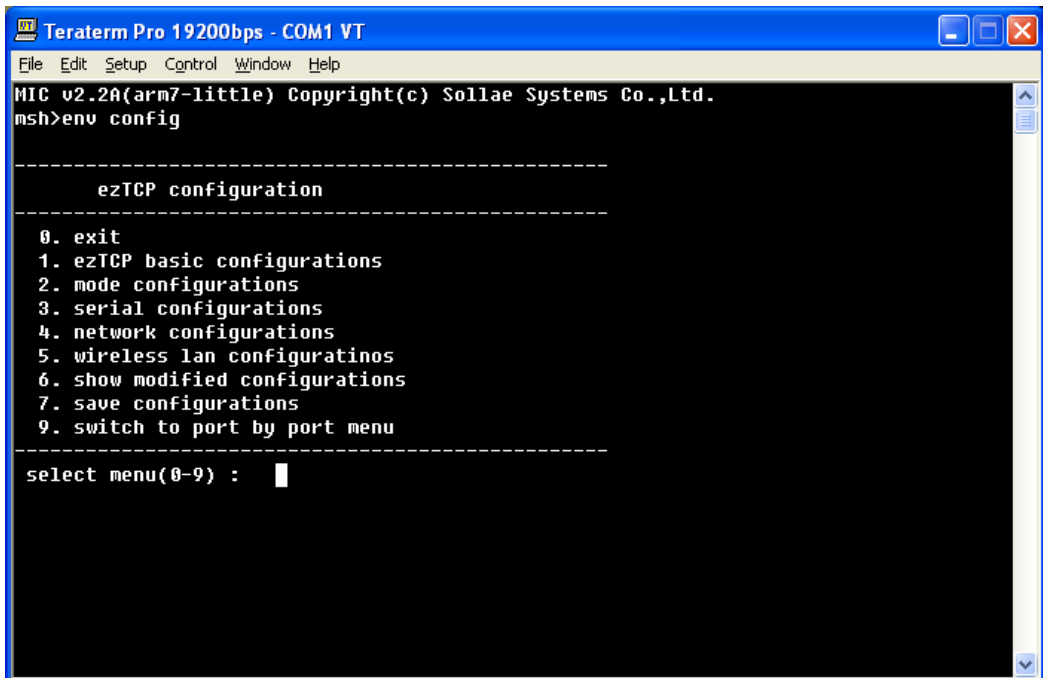

Its structure is followed:

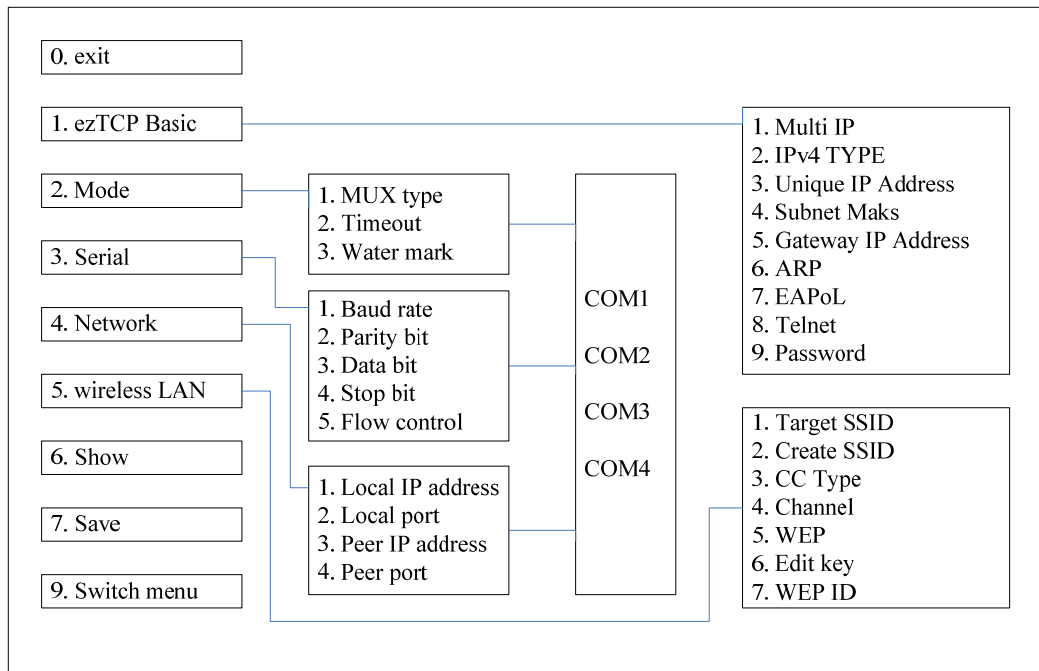

If user inputs 'env ext' in the Console Mode, the following screen will be shown.

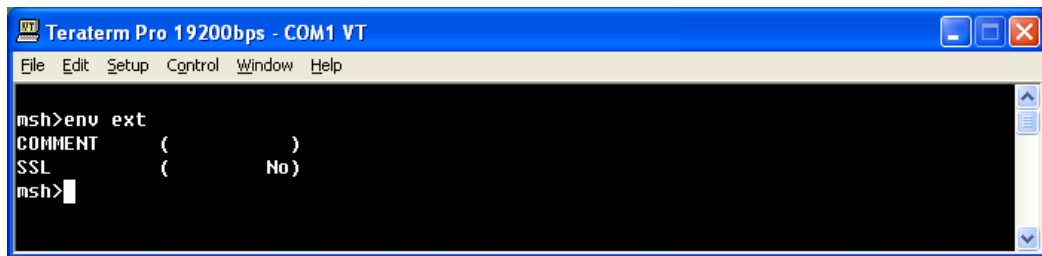

---

## 4. The Operation Mode of EZL-400S

EZL-400S can operate in one of two modes (Normal Communication, Console). Normal Communication Mode is ordinary data communication mode; Console mode is used to configure the environmental variables through the serial port.

### 4.1. Normal Communication Mode

Normal communication mode is suitable for the purpose of using EZL-400S.

Normal communication mode can be classified into four modes – T2S, ATC, COD, and U2S – each of which is described in the following table.

Each COM ports operate independently according to [MUX Type].

	T2S	ATC	COD	U2S
Protocol	TCP	TCP	TCP	UDP
Function	Server	Server/Client	Server	-
Topology	1:1	1:1	1:1	N:M

☞ *For more information about Normal Communication Mode, refer to next chapter.*

### 4.2. Console Mode

The Console Mode is that the COM1 port operates as console port. All security functions are disabled in this mode. If user presses a button the front side of the EZL-400S over 1 second, EZL-400S operates as Console Mode. In this mode, [RUN] LED and [STS1] LED blink at the same time. The settings of COM1 port in the Console Mode are followed:

Buadrate	19200 bps
Data bits	8 bits
Stop bit	1 bit
Parity bit	None
Flow Control	None

---

## 5. Normal Communication Mode

### 5.1. T2S

#### 5.1.1. Communication

In T2S mode, the EZL-400S functions as a server.

When a host connects to predefined local port, the EZL-400S accepts a TCP connection. When the EZL-400S accepts TCP connection, then the TCP connection is established. After connection is established, TCP/IP processing is performed on the data coming to the serial port, which is then transmitted to the remote host. And the TCP/IP data coming from the remote host is TCP/IP-processed and transmitted to the serial port to establish data communication. (Data coming to the serial port before TCP connection is established will be ignored.)

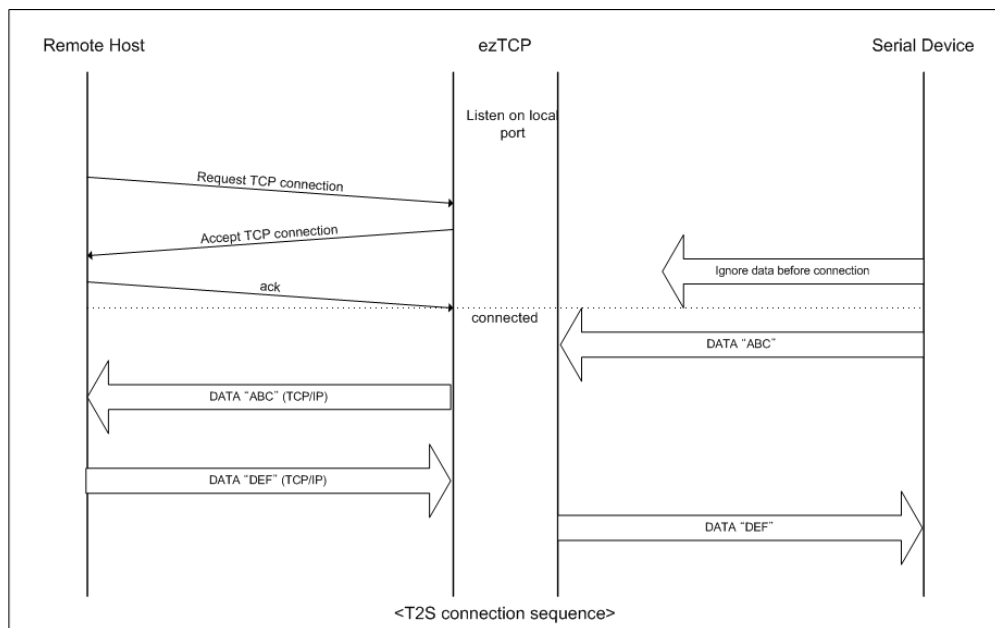

#### 5.1.2. Connection Termination and Keep Alive Function

If [Timeout] is set, EZL-400S terminates the connection if there is no data transmission for pre-defined time ([Timeout] sec). If [Timeout] is set to 0, EZL-400S sends a keep alive packet every 10 seconds. If there is no response 5 consecutive times from the foreign host, EZL-400S terminates the connection.

## 5.2. ATC

In ATC mode, the user can control the EZL-400S in a similar way to controlling the modem using AT command. In ATC mode, only a TCP connection is possible and both the server and the client can be configured.

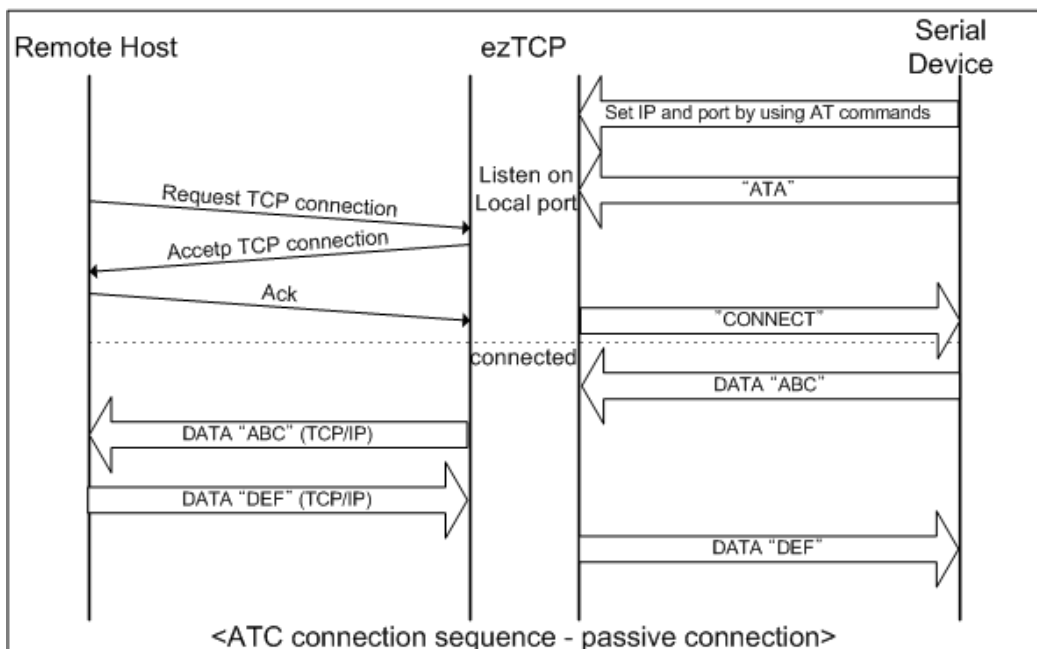
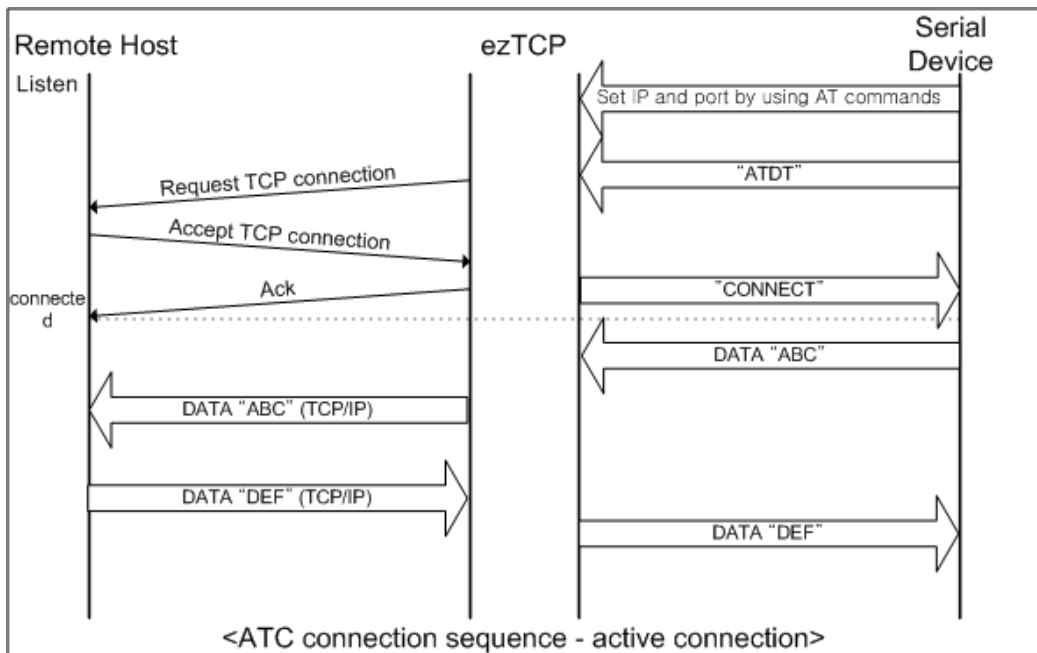

☞ Refer to "6. ATC Mode" for more information.

## 5.3. COD

### 5.3.1. Communication

In COD mode, the EZL-400S functions as a client.

When data of the pre-specified size [Water Mark] comes to the serial port, the EZL-400S attempts a TCP connection to the TCP port [Peer Port] of the preset host IP [Peer IP Address]. If the remote host accepts the TCP connection, TCP connection will be established. Data coming to the serial port after connection establishment is TCP/IP-processed and transmitted to the remote host. And, data coming from the remote host is TCP/IP-processed and transmitted to the serial port for data communication.

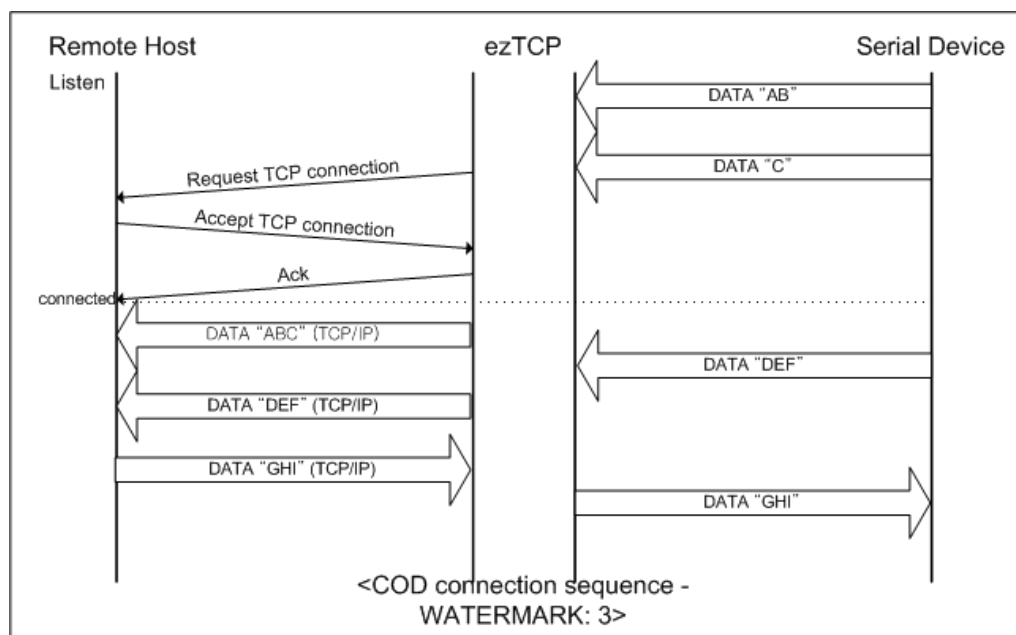

### 5.3.2. Connection Termination and Keep Alive Function

If [Timeout] is set, EZL-400S terminates the connection if there is no data transmission for pre-defined time ([Timeout] sec). If [Timeout] is set to 0, EZL-400S sends a keep alive packet every 10 seconds. If there is no response 5 consecutive times from the foreign host, EZL-400S terminates the connection.

### 5.3.3. Reconnection

After disconnection, EZL-400S doesn't attempt to connect for 10 seconds.

## 5.4. U2S

U2S mode allows for UDP communication.

In UDP mode, data are transmitted in blocks, which require dividing data coming to the serial port into blocks before transmitting data. A procedure for dividing data into blocks is as follows:

If data of pre-specified bytes [Water Mark] comes to the serial port of the EZL-400S or if a specified period of time [Timeout] elapses after first data reception, all data received for the same period is recognized as one block which is then transmitted to the UDP. The [Timeout] unit is 10ms. If [Timeout] is set to 2, the time period is between 20ms and 30ms.

Since UDP communication does not require a connection procedure, the user can establish N-to-M communication via broadcast.

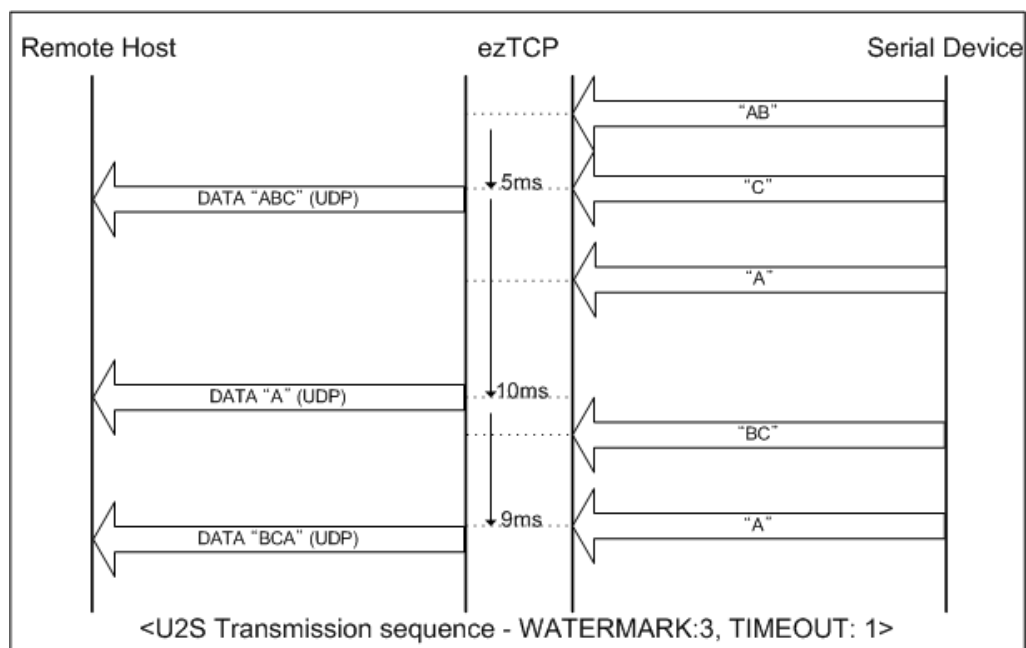

*√ SSL protocol cannot be used in U2S, because SSL works over TCP.*

## 6. ATC Mode

### 6.1. Overview

EZL-400S can be controlled by AT commands in ATC mode. For example, the peer host IP address can be set by AT+PRIP command and connect to the host by ATD command.

Therefore, EZL-400S communicates several hosts alternatively.

And also, it provides passive connection function by ATA command.

#### 6.1.1. AT command format

AT commands start with AT, and end <CR>.

AT command format is followed.

AT	Command	<CR>(0x0d)
----	---------	------------

The response code to AT command is followed.

Response message	<CR>(0x0d)	<LF>(0x0a)
------------------	------------	------------

Response Message

When ATV1 (initial setting)	When ATV0	Description
OK	0	command OK
CONNECT	1	TCP connected
NO CARRIER	3	TCP disconnected
ERROR	4	Command error
Set value	Set value	When query set value (example: AT+PRIP?)

### 6.2. Basic AT Command Set (Example: ATA, ATD etc.)

Command	Function	Description
A	passive connection	Listen connection (host → EZL-400S connection)
D	active connection	Connecting to host form EZL-400S
E	echo	Echo (E0 - no echo, E1-echo)
H	off-hook	disconnection
I	Inquiry	Output EZL-400S related-information
O	Online	To online mode
V	enable result code	Result code (numeric-V0, alphabetic-V1)

Z	reset	Reset
---	-------	-------

### 6.3. Extended AT Commands (Example: AT+PLIP etc.)

Command	Function	Description
+PLP	listening TCP port	
+PTO	timeout	
+PRIP	Remote machine IP address	
+PRP	Remote machine TCP port	

### 6.4. Online State and Online Command State

It is online command mode when TCP is being disconnected. AT commands can be used in online command mode. After TCP connection, AT commands cannot be used. To use AT commands during the connection, change state to online command state.

Online Command State	During TCP disconnected, AT commands can be used To use AT commands during the connection, required escape sequence
Online State	During TCP connected, all serial data to EZL-400S convert TCP and send to the network.

#### 6.4.1. Changing Online State to Online Command State

To change online state to online command state during the connection, +++ string should be transmitted to EZL-400S as following time interval.

When transmitting +++ string to EZL-400S, +++ string will be sent to peer host.

The time from final data the first '+' data of '+++' string	No data over 500ms(guard time)
time intervals between '+'s	0~500ms
Time interval after receiving last '+'	No data over 500ms (guard time)

#### 6.4.2. Changing Online Command State to Online State

If EZL-400S's state is in online command state during TCP connection, EZL-400S's state can be changed into online state by an ATO command.

## 6.5. Example of TCP Connection

### 6.5.1. Example of Active Connection

	Serial Port		Description
	AT+PRIP=192.168.1.201<CR>	▶	Setting remote IP address to connect
◀	<CR><LF>OK<CR><LF>		Command OK
	AT+PRP=1470<CR>	▶	Setting remote port number to connect
◀	<CR><LF>OK<CR><LF>		Command OK
	ATDT<CR>	▶	Connecting to the host
Attempting to connect to the host			
◀	<CR><LF>CONNECT<CR><LF>		TCP connection success
Data Communication			

### 6.5.2. Example of passive Connection

	Serial Port		Description
	AT+PLP=1470<CR>	▶	Set LOCAL PORT to listen
◀	<CR><LF>OK<CR><LF>		Command OK
	ATA<CR>	▶	Passive connection command
Listen on local port from a host			
A host connects to EZL-400S			
◀	<CR><LF>CONNECT<CR><LF>		TCP connection OK
Data Communication			

## 6.6. Example of TCP Disconnection

### 6.6.1. Example of active disconnection

EZL-400S disconnects the connection.

	Serial Port		Description
Data Communication(during TCP connection)			
	[guard time]+++[guard time]	▶	Changing online state to online command state
◀	<CR><LF>OK<CR><LF>		Changed to online command state
	ATH	▶	TCP disconnection command
◀	<CR><LF>OK<CR><LF>		Command OK

## 6.6.2. Example of passive disconnection

The remote host disconnects the connection.

	Serial Port		Description
Data Communication(during TCP connection)			
The remote host disconnect the connection			
◀	<CR><LF>NO CARRIER<CR><LF>		TCP disconnected

---

## **7. Technical Support, Warranty, and Notes on Operation**

### **7.1. Technical Support**

If you have any question regarding operation of the product, visit Customer Support FAQ corner and the message board on Sollae Systems' web site or send us an email at the following address: [support@eztcp.com](mailto:support@eztcp.com)

Website Address for Customer Support:

<http://www.sollae.co.kr>

### **7.2. Warranty**

#### **7.2.1. Refund**

Upon the customer's request to refund the product within two weeks after purchase, Sollae Systems will refund the product.

#### **7.2.2. Free Repair Services**

For product failures occurring within one year after purchase, Sollae Systems provides free repair services or exchange the product. However, if the product failure is due to user's fault, repair service fees will be charged or the product will be replaced at user's expense.

#### **7.2.3. Charged Repair Services**

For product failures occurring after the warranty period (one year) or resulting from user's fault, repair service fees will be charged and the product will be replaced at user's expense.

#### **7.2.4. Notes on Operation**

- Sollae Systems is not responsible for product failures occurring due to user's alternation of the product.
- Specifications of the product are subject to change without prior notice for performance improvement.

- Sollae Systems does not guarantee successful operation of the product if the product was used under conditions deviating from the product specifications.
- Reverse engineering of firmware and applications provided by Sollae Systems is prohibited.
- Use of firmware and applications provided by Sollae Systems for purposes other than those for which they were designed is prohibited.
- Do not use the product in an extremely cold or hot place or in a place where vibration is severe.
- Do not use the product in an environment in which humidity is high or a lot of oil exists.
- Do not use the product where there is caustic or combustible gas.
- Sollae Systems does not guarantee normal operation of the product under the conditions a lot of noise exists.
- Do not use the product for a purpose that requires exceptional quality and reliability relating to user's injuries or accidents - aerospace, aviation, health care, nuclear power, transportation, and safety purposes.
- Sollae Systems is not responsible for any accident or damage occurring while using the product.

---

## 8. Revision History

Date	Version	Comments
Dec.02.2005	1.1	The first release