

ARM microPCBoard

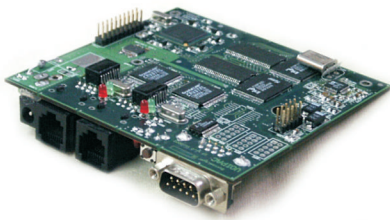
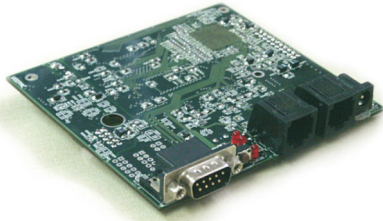

ARM microPCBoard

This board was primary designed for IP phone. It contains two network interfaces, one for the network connection and the other one for connecting PC. There is audio interface inbuilt, which was necessary for IP phone. In case of development price-sensitive application where top performance is not required, Light version of the board is suggested to use. For more challenging tasks where more powerful CPU and larger memory storage is required customer can use PRO version of the board. The board can be also used as network component like a firewall or router/switch etc. In such cases the board is delivered without audio interface which results into purchase price reduction. The board is supplied upon request in stylish case.

Linux operating system is preinstalled on the board as default. Board is manageable through standard Rs232 serial link. For the effective work user should use usual terminal station. Later when network interfaces are configured user can manage whole system remotely via LAN/internet using SSH protocol. Also remote software upload/upgrade is supported by system. In FLASH memory can be stored customer made applications. The board can be delivered also without preinstalled operating systems. For more information refer to technical specification of the board.

Hardware Specifications

Common to all types of the board

- 1 or 2 x 10Mb Ethernet (cs89x0)
- RS232 connector, output to terminal
- UART serial connector (3.3-5V)
- JTAG connector
- AC97 audio (Optional) - stereo line IN/OUT, mono microphone input, Mono/Stereo headphones output
- FLASH-erase-protection switch
- 3 x LED
- RESET switch
- Power: 7,5V (connector: 5.5x2.1mm, center positive), power consumption up to 5W
- Size: 100 x 107 x 27 mm
- Temperatures: 0°C to +70°C (commercial version)
-40°C to +85°C (industrial version, without audio)

Depending on type of board:

ARM microPCBoard Light

- Intel PXA250 / 200MHz Processor
- 8MB FLASH memory
- 32MB SDRAM memory

ARM microPCBoard Standard

- Intel PXA250 / 300MHz Processor
- 32MB FLASH memory
- 32MB SDRAM memory

ARM microPCBoard PRO

- Intel PXA255 / 400MHz Processor
- 32MB FLASH memory
- 64MB SDRAM memory

Software specifications

OS Linux version 2.4.19-rmk4-pxa2

- File systems (ROMFS, JFFS2, EXT2, NFS, RAMFS)
- Terminal
- SSH, TFTP
- LINUX basic utilities (Bash, Vi, ...)
- Network drivers
- Demo MP3 player

Typical Application

- Firewall
- Router
- IP telephony
- Embedded Systems
- Automatization, Industry
- Security systems
- Mobil devices (GSM/GPRS)



POWERED BY
Linux

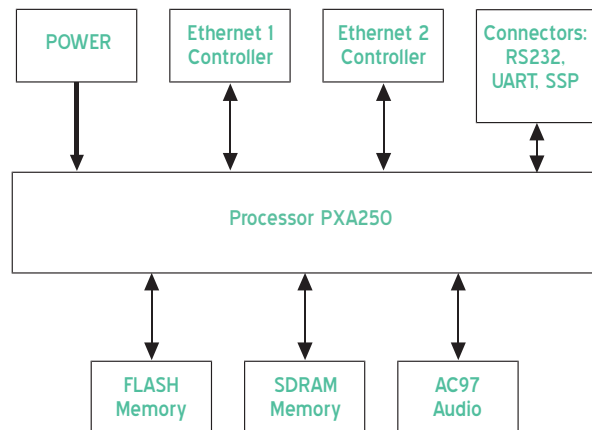

www.voipac.com

voipac

Voipac, s.r.o., Janka Kráľa 3
911 01 Trenčín, Slovak Republic
Phone: +421 32 653 85 55
Fax: +421 32 653 85 33
Email: info@voipac.com
Web: www.voipac.com

Connectors

Audio connector

Pin	Description
1	LINE_IN_L *
2	LINE_OUT_L
3	LINE_IN_R *
4	LINE_OUT_R
5	AGND
6	MONO_OUT *
7	MIC1_IN
8	HP_OUT_L
9	MIC1_REF
10	HP_OUT_R

* Optional

SP1 3-5V (5V tolerant I/O pins accept 5V,3.3V)

Pin	Description
1	VCC5
2	VCC3.3
3	SP1_BT_CTS
4	GND
5	SP1_BT_RTS
6	GND
7	SP1_BT_RXD
8	GND
9	SP1_BT_TXD
10	GND

SP0-RS232 (V.28 voltage level)

Pin	Description
1	SP0_RXD
2	SP0_CTS
3	SP0_DCD
4	SP0_DSR
5	SP0_RI
6	SP0_TXD
7	SP0_RTS
8	SP0_DTR
9	GND
10	GND

RS232 (V.28 voltage levels)

Pin	Description
1	SP0_DCD
2	SP0_RXD
3	SP0_TXD
4	SP0_DTR
5	GND
6	SP0_DSR
7	SP0_RTS
8	SP0_CTS
9	SP0_RI

The same port

SSP (5V tolerant I/O pins accept 5V,3.3V)

Pin	Description
1	VCC5
2	VCC3.3
3	SSP_FRM
4	GND
5	SSP_CLK
6	GND
7	SSP_TXD
8	GND
9	SSP_RXD
10	GND

JTAG connector

Pin	Description
1	VREF (VCC3.3)
2	VCC3.3
3	-TRST
4	GND
5	TDI
6	GND
7	TMS
8	GND
9	TCK
10	GND
11	RTCK
12	GND
13	TDO
14	GND
15	-RESET
16	GND
17	NC
18	GND
19	NC
20	GND

Settings

Serial console settings

- Baud rate: 38400
- Data bits: 8
- Parity: none
- Stop bits: 1
- Flow control: none

Jumper settings

JP331 - Flash Erase

- ENABLE (with jumper)
- DISABLE (without jumper)

Login to system

There are two possibilities, via *serial console* or SSH session.

Serial console

Use null modem cable, connect it to RS232 on PXABoard and computer. Start terminal on computer (Hyperterminal, TeraTerm, Minicom, ...) with 38400 baud rate, 8 data bits, None Parity, 1 Stop-Bit, None Flow Control.

SSH session

Run SSH (Putty, cygwin, OpenSSH, ...) to address specified in shipment.

Set username "root" and password "root".

File system

Flash of capacity 8(16)MB is divided into 3 partitions. First 256kB partition is used for BootLoader. On second 768kB partition resumes LinuxKernel. The last one of rest capacity is filesystem JFFS2(rw). That means you can copy or create any file on it up to the capacity resources.

Write Flash from Linux

Block Devices

```
/dev/mtdblock0 (BootLoader)
/dev/mtdblock1 (LinuxKernel)
/dev/mtdblock2 (FileSystem)
```

Character Devices

```
/dev/mtd0 (BootLoader,rw)
/dev/mtd1 (BootLoader,ro)
/dev/mtd2 (LinuxKernel,rw)
/dev/mtd3 (LinuxKernel,ro)
/dev/mtd4 (FileSystem,rw)
/dev/mtd5 (FileSystem,ro)
```

Examples

to erase LinuxKernel partition:

```
eraseall /dev/mtd2
```

to write new LinuxKernel:

```
cat newkernel > /dev/mtd2
```

to mount folder 's':

```
mount /dev/mtdblock2-t jffs2 s
```

Write Flash from JTAG

JP331 on PXABoard is ON. Connect JTAG to the PXABoard and to LPT port on the computer (Windows running).

Run "*instdrv giveio c:\winnt\system32\drivers\giveio.sys*"
To write data from FILE to partition 1 (partitions start from 0) run "*Jflash.exe FILE P 1*"
PopUp window arrives on the screen with processing information.

